

**STANDARD PROJECTILE IMPACT TEST METHOD AND
EQUIPMENT USED IN EVALUATING THE
PERFORMANCE CHARACTERISTICS OF
PROTECTIVE HEADGEAR,
FACEGUARDS OR PROJECTILES**

NOCSAE DOC (ND) 021- 98m09

Prepared By -



**NATIONAL OPERATING COMMITTEE
ON STANDARDS FOR ATHLETIC EQUIPMENT**

Modified - July 2009

TABLE OF CONTENTS

SCOPE.....	1
REFERENCED DOCUMENTS	1
SPECIFIC TERMINOLOGY.....	1
SIGNIFICANCE AND USE.....	2
SUMMARY OF TEST METHOD	3
HEADGEAR	3
PROJECTILES.....	3
CERTIFICATION	3
CONSTRUCTION.....	3
MATERIALS	3
LABELING & INSTRUCTIONS	4
HEADGEAR LABELING	4
PROJECTILE LABELING	5
SAMPLES FOR TESTING.....	6
CONDITIONING	6
IMPACT TEST INSTRUMENTS AND EQUIPMENT	6
APPENDIX 1.....	10
JANUARY, 2002 MODIFICATIONS/REVISIONS.....	11
APRIL, 2003 MODIFICATIONS/REVISIONS	11
APRIL , 2003 MODIFICATIONS/REVISIONS.....	11
JANUARY, 2004 MODIFICATIONS/REVISIONS.....	11
FEBRUARY, 2005 MODIFICATIONS/REVISIONS	11
DECEMBER, 2005 MODIFICATIONS/REVISIONS	11
JANUARY, 2008 MODIFICATIONS/REVISIONS.....	11
JULY, 2009 MODIFICATIONS/REVISIONS.....	11

1. Scope

- 1.1 This standard test method describes laboratory equipment and basic requirements pertinent to projectile impact testing of protective headgear or certain projectiles. Deviations, additions or both, to this test method will be specified, as required, in individual standard performance specifications.
- 1.2 ***All testing and requirements of this standard specification must be in accordance with NOCSAE DOC.001 where appropriate.***
- 1.3 This standard test method is limited to use with products associated with specific NOCSAE standards.
- 1.4 *This standard does not purport to address all of the safety problems, if any, associated with its use. It is the responsibility of the user of this standard to establish appropriate safety and health practices plus determine the applicability of regulatory limitations prior to use.*

2. Referenced Documents

- 2.1. STANDARD DROP TEST METHOD AND EQUIPMENT USED IN EVALUATING THE PERFORMANCE CHARACTERISTICS OF PROTECTIVE HEADGEAR, NOCSAE DOC.001
- 2.2. TEST METHOD FOR COMPRESSION-DISPLACEMENT OF BASEBALLS AND SOFTBALLS, ASTM F1888
- 2.3. TEST METHOD FOR COEFFICIENT OF RESTITUTION FOR BASEBALLS AND SOFTBALLS, ASTM F 1887

3. Specific Terminology

- 3.1. See Section 3, NOCSAE DOC.001.
- 3.2. Descriptions of terms specific to this standard
 - 3.2.1. Baseball: Any such ball defined by the rules of the game as published by the sports' governing bodies.
 - 3.2.2. Mass: The weight of the ball as measured by a scale. Reported in ounces (oz).
 - 3.2.3. Compression-Displacement Load (C-D): The reaction force or load due to a specified displacement of compression of the test specimen. Reported in units of pounds force (lbs.) accompanied by either the percentage of sample displacement or a fixed displacement value. For example 25% C-D equals 200 lbs.
 - 3.2.4. Compression-Displacement Curve: The relationship between compression and displacement often viewed by graphing the values of compression versus displacement.

- 3.2.5. Coefficient of Restitution (COR): A measure of energy loss during rebound. Calculated as out-bound velocity divided by in-bound velocity. Values range from 0 (complete energy loss) to 1 (no energy loss). Reported as a ratio of velocities and thus has no units.
- 3.2.6. Displacement: The reduction in a specimen's diameter measured as the change in distance between two flat plates. Reported in units of inches (in) or percentage of original sample.
- 3.2.7. Projectile: Any hurled or struck body that is used as an integral component of the sport being played that has the potential of contacting a player of that sport.
- 3.2.8. Linear Bearing Table: A sliding table top fitted with the necessary supports to position a headform at various angles and rotations in order to facilitate projectile impacts at the designated locations. This table may be mounted to a separate device that allows for rapid elevation adjustments.
- 3.2.9. Critical sizes are defined as follows:
- 3.2.9.1. The helmet's "Stetson" size that corresponds to the correct headform's "Stetson" size.
 - 3.2.9.2. The thinnest padding configuration for a particular helmet shell on the smallest headform designated for the selling size range for that particular shell.
- 3.2.10. Low Temperature: Expose product to conditioned temperature of $32^{\circ}\text{F} + 0^{\circ}\text{F}$ or -3°F ($0^{\circ}\text{C} + 0^{\circ}\text{C}$ or -1°C) for at least four hours.

4. Significance and Use

- 4.1. The purpose of this test method is to provide reliable and repeatable measurements for the evaluation of various types of protective headgear and/or projectiles. This test method is based on pass/fail criteria only for SI and within specified tolerances for other measures.
- 4.2. A passing headgear is able to withstand the impact at an acceptable SI and meets all other requirements of the Performance Specifications when tested in accordance with this test method.
- 4.3. A passing projectile is able to meet the mass, circumference, COR and CD values for a given level to be certified to that level and meets all other requirements of the Performance Specifications when tested in accordance with this test method.
- 4.4. This test method must be used in conjunction with the specific individual standard performance specifications relative to a specific activity.

5. Summary of Test Method

- 5.1. Headgear: A headgear is positioned on a headform that is rigidly mounted on a linear bearing table to achieve a somewhat realistic post impact situation. The projectile is propelled at the headgear such that the impact velocity is within 3% of the specified velocity. At impact, the instantaneous resultant acceleration is measured by a triaxial accelerometer and the Severity Index calculated.
- 5.2. Projectiles: A projectile is propelled to strike a steel or ash block that is rigidly mounted to substantial vertical surface. A projectile is propelled at the block such that the impact velocity is within 3% of the specified velocity. Projectiles may also be subjected to other mechanical testing.

6. Certification

- 6.1. NOCSAE publishes standards but does not conduct surveillance to assure compliance to standards. It is the sole responsibility of firms that manufacture or recertify protective headgear and projectiles to certify that the requirements of these standards are met. It is recommended that firms utilize independent test laboratories at least annually to test each model and size of protective headgear.

7. Construction

- 7.1. General: Headgear shall be constructed to reduce the acceleration of the wearer's head, and to remain on the wearer's head, during impact. Optional devices fitted to the headgear shall be designed so that they are unlikely to cause injury during use.
- 7.2. Projectiles shall be constructed without sharp edges.
- 7.3. Headgear must survive all test protocols substantially intact and ready for use.
- 7.4. Projectiles must survive all test protocols substantially intact and ready for use.
- 7.5. Projections in Headgear: Any internal rigid projections that may contact the wearer's head during impact shall be covered so as to reduce the likelihood of injury.

8. Materials

- 8.1. Materials used in the headgear shall be durable and resistant to exposure to sun, rain, cold, dust, vibration, perspiration and products likely to be applied to the skin or hair. Materials known to cause skin irritation or disease shall not be used. Lining materials, if used, may be detachable for washing. If hydrocarbons, cleaning fluids, paints, transfers/decals or other additions will affect the headgear adversely, a warning shall be provided.
- 8.2. Materials used in projectiles shall be such that any wear and tear from normal use will not result in loss of physical properties as measured in this test method.

9. Labeling & Instructions

- 9.1. Headgear Labeling - Each headgear shall be permanently and legibly labeled or marked in a manner such that the following information can be easily read and is not obscured in any manner.
 - 9.1.1. Name of Manufacturer
 - 9.1.2. Model Designation
 - 9.1.3. Size
- 9.2. Each headgear shall be permanently and legibly labeled or marked in a manner such that the following additional information can be easily read without removing any permanent component. These labels shall contain a signal word which shall not be obscured in any manner:
 - 9.2.1. A label that warns the user that no headgear can protect against all possible impacts; and, that for maximum performance, the headgear must be fitted and attached properly to the wearer's head in accordance with the manufacturer's fitting instructions.
 - 9.2.2. A label that warns the user that the headgear can be damaged by contact with common substances (for example, certain solvents, cleaners, hair tonics, etc.) and that this damage may or may not be visible to the user. This label should also list any recommended cleaning agents or procedures, or both.
 - 9.2.3. Warnings: Each headgear shall have appropriate warning information as called for in the individual performance specifications.
- 9.3. Individual standard performance specifications may require additional labeling or marking on the interior or exterior of the product, or both.
- 9.4. A permanent and legible label or mark that denotes the month and year of manufacture that can be easily read without removing any permanent component. If this mark or label requires a "code" to determine month and year, such code shall be made available upon request.
- 9.5. Each headgear must have fitting/positioning instructions provided; such instructions will include reference to any required components for headgear function.

9.6. A legible, permanent replica of one of the appropriate seals (shown below) shall appear on the exterior of the headgear, see note below seals.

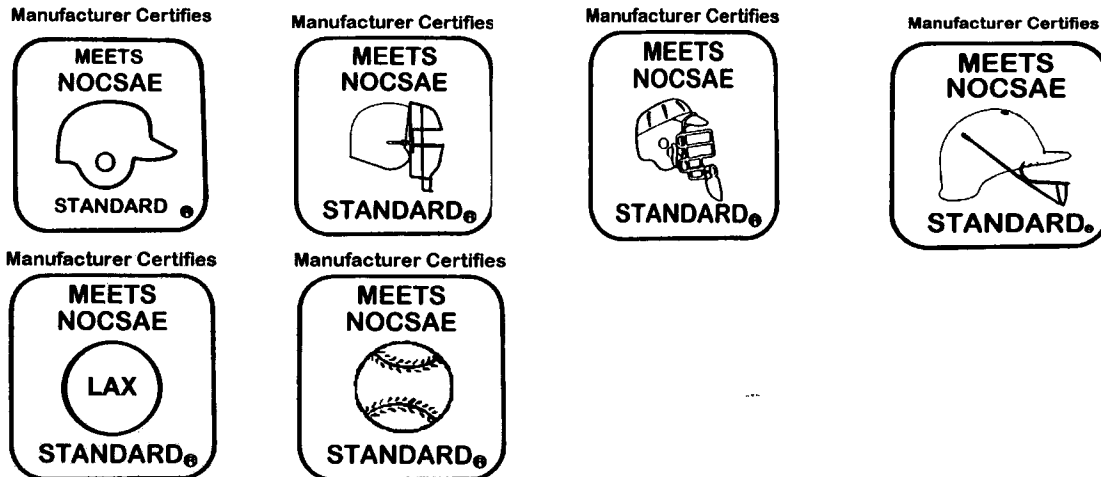

NOTE: You must have an executed, valid license agreement with NOCSAE to use any of the NOCSAE logos at any time. NOCSAE, the NOCSAE seals/logos, and the National Operating Committee on Standards for Athletic Equipment are registered marks and the exclusive property of the Committee. Use of the marks in any manner is prohibited without prior written permission of the NOCSAE Board of Directors. In place of manufacturer certifies the manufacturer may use it's own name i.e., xyz company certifies "MEETS NOCSAE STANDARD" This seal maybe scaled so long that it remains legible.

9.7. Projectile Labeling

9.7.1. Each projectile shall be permanently and legibly labeled in a manner such that the following information can be easily read -

9.7.1.1. Name of Manufacturer

9.7.1.2. Model Designation

9.7.1.3. The phrase, "Meets NOCSAE Standard"

9.7.2. Packaging for projectiles shall be permanently and legibly labeled in a manner such that the following information can be easily read -

9.7.2.1. Month and year of manufacture

9.7.2.2. A label that warns the user that no projectile can prevent all injuries at any velocity; and, that for added protection against projectiles, a helmet and face protector should be worn.

- 9.7.3. Warnings: Each projectile shall have appropriate warning information as called for in the individual performance specifications.

10. Samples for Testing

- 10.1. Headgear shall be tested complete, in the condition as offered for sale or use unless specified otherwise in an individual Performance Specification.
- 10.2. Projectiles shall be tested in the condition as offered for sale or use unless specified otherwise in an individual Performance Specification.
- 10.3. Headgear/projectiles used for testing must be selected in a random manner.

11. Conditioning

See Section 12, NOCSAE DOC.001.

12. Test Instruments and Equipment

- 12.1. Projectile launching device capable of propelling the specified projectile to the specified velocity within 3% and having a targeting device that allows impacts within a $\frac{1}{4}$ in. radius 24 in. from the muzzle or the point at which the projectile is first in "free flight." For COR testing the device shall be able to return the projectile to the point of launch at the muzzle within the variation specified.
- 12.2. A Strike Plate that is either a 2 ± 0.01 in. (5.08 ± 0.025 cm) thick steel plate or a 4 ± 0.01 (10.2 ± 0.025 cm) thick northern white ash wood block with a moisture content between 10-15%, that is at least 24.0 in. (61 cm) square, mounted flush to a massive rigid wall of cinder block or concrete, minimally 8 in. (20.3 cm) thick as perpendicular to the line of flight of the ball as possible such that a baseball propelled towards the strike plate will rebound to within a 6 in. circular target located 2 feet from the strike plate.
- 12.3. Electronic speed monitors capable of measuring the in-bound and rebound velocity of a ball when it is propelled at the strike plate through two gates at speeds of 60.0 ± 2.0 mph. The first gate is mounted 24 ± 0.125 in from the strike plate and the second gate is mounted 12 ± 0.125 in from the first gate. A "proof of accuracy" method (such as a paper target or high speed video) is required to determine that the trajectory of the ball does not deviate more than 6 in while traveling through the light gates before and after impact with the strike plate before and after each series of tests.
- 12.4. The entire moving assembly of the linear bearing table and the supporting headform apparatus that may be in motion during or after an impact shall not exceed $5.7 \text{ kg} \pm 0.5$ kg. This aggregate weight does not include the headform or the headform coupler.
- 12.5. Recommended Air Cannon Assembly Including Linear Bearing Table Assembly (See Figures 1 and 2)

12.6. See Section 15, NOCSAE DOC.001

12.6.1. See Appendix 1 to verify headform response prior to impact testing.

- 12.7. Projectiles used as part of the test method as a means of delivering an impact to an item subject to testing, the projectile shall meet the mechanical requirements for mass, compression/deflection and size for the specific projectile as specified in the individual Performance Specifications.
- 12.8. A device for measuring the weight of an object with a mass between 10g and at least 500g with a resolution of 0.1 g and displaying results in oz.
- 12.9. A compression device capable of producing a compressive force of at least 500 lbs. with a resolution of at least 0.05 lbs. The device must have enough clearance to allow compression of an object that is in excess of 5 inches in diameter at a variable rate from at least ½ to 2 inches per minute. The platens applying load to the ball shall be flat.

This standard is subject to revision at any time by the responsible technical authority and must be reviewed every five years and if not revised either reapproved or withdrawn. Your comments are invited either for revision, modification or creation of additional standards and should be addressed to NOCSAE's Executive Director. Check the web at www.nocsa.org to obtain the latest version of a standard.

This standard is copyrighted by NOCSAE 11020 King Street, Suite 215 Overland Park, Kansas 66210 USA. Copies may be obtained from the NOCSAE web site at www.nocsa.org

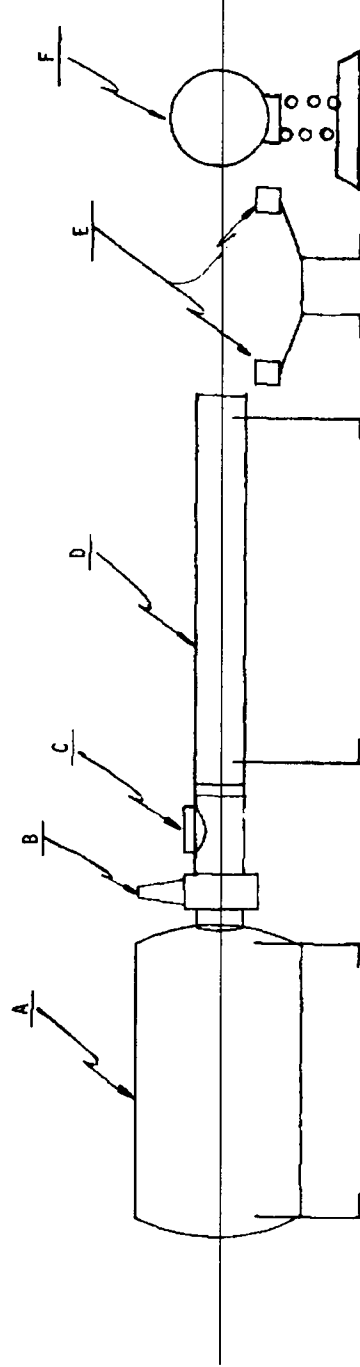

This is an exemplary system; any system that provides the required test parameters is acceptable.

- A = air reservoir
- B = air solenoid
- C = loading breech
- D = interchangeable barrel
- E = velocity measurement sensors
- F = head form—fully adjustable 3 axis and rotation

FIG. 1 Ball Propelling Device

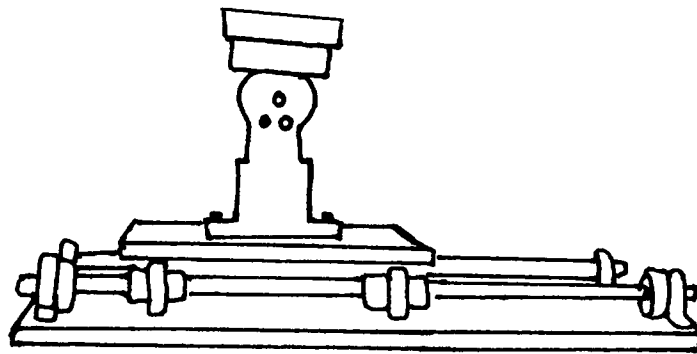

Linear Bearing Table - Figure 2

Appendix 1 Procedure for Verification of NOCSAE Headforms Projectile Response

Prior to commencing the verification, carefully inspect all equipment to ensure your lab's mechanical system is in proper working order.

Verification Protocol:

Step 1: Tune channel voltages on the KME system to 1.00V.

Step 2: Obtain a baseball with the following properties:

- weight: 140–145 grams
- circumference: 9.00–9.25 inches
- compression - deflection: 200–300 lbs
- constructed as specified by Major League Baseball

Note: A Rawlings Major League Baseball, model #RO-MLB, is the ball mostly likely to meet this criteria, however you should refer to NOCSAE DOC(ND) 027 – 04m06 for procedures to determine if the mechanical properties required are in fact the properties of the ball you use to verify headform response. Failure to verify ball properties prior to headform verification will result in suspect data.

Step 3: Impact the headform in the standard right side as described in Section 19, NOCSAE DOC.001 at each of the following velocity ranges. Record the values and perform a review.

Small (Red) HEADFORM	Medium (Blue) HEADFORM	Large (Green) HEADFORM
30 +/- 1 mph	34 +/- 1 mph	36 +/- 1 mph
32 +/- 1 mph	36 +/- 1 mph	38 +/- 1 mph
34 +/- 1 mph	38 +/- 1 mph	40 +/- 1 mph
36 +/- 1 mph	40 +/- 1 mph	42 +/- 1 mph
38 +/- 1 mph	42 +/- 1 mph	44 +/- 1 mph
40 +/- 1 mph	44 +/- 1 mph	46 +/- 1 mph
42 +/- 1 mph	46 +/- 1 mph	48 +/- 1 mph

Step 4: Determine if your headforms have the appropriate response.

- Small headforms should pass through 1200 SI between 32-40mph
- Medium headforms should pass through 1200 SI between 36-44mph
- Large headforms should pass through 1200 SI between 38-46mph.

If you have any questions as to how to perform this procedure, contact Southern Impact Research Center at info@soimpact.com

JANUARY, 2002 MODIFICATIONS/REVISIONS

- Simplified document references within document.

APRIL, 2003 MODIFICATIONS/REVISIONS

- Section 12.1, added polo ball to description of device capable of propelling balls.
- Section 9, updated labeling instructions to include placement of date on product and updated the requirements for projectile labeling.
- Section 2.3, added references to ASTM test methods F 1887 and F 1888.

JANUARY, 2004 MODIFICATIONS/REVISIONS

- Added additional terminology related to NOCSAE Doc ND027
- Added additional verbiage related to Doc ND027
- Added equipment relative to NOCSAE Doc ND027
- Changed seal/logo document to allow use of the manufacturers name in place of the word Manufacturer.

FEBRUARY, 2005 MODIFICATIONS/REVISIONS

- Modified section 9.5 to clarify fitting/positioning instructions.

DECEMBER, 2005 MODIFICATIONS/REVISIONS

- Added Lacrosse ball and baseball NOCSAE logos.

JANUARY, 2008 MODIFICATIONS/REVISIONS

- Modified Section 9 placement of date code

July 2009 MODIFICATIONS/REVISIONS

- Added Section 12.6.1
- Added Appendix 1