

**STANDARD TEST METHOD
AND PERFORMANCE
SPECIFICATION FOR
NEWLY MANUFACTURED
SOCCER SHIN GUARDS**

NOCSAE DOC (ND) 090 – 06m09

Prepared By



**NATIONAL OPERATING COMMITTEE
ON STANDARDS FOR ATHLETIC EQUIPMENT**

Modified – May 2009

Table of Contents

Scope	1
Referenced Documents	1
Referenced Documents	1
Terminology	1
Samples for Testing	3
Sample Size.....	3
Certification.....	3
Test Equipment.....	3
Marking the Impact Area	4
Extent of Coverage	5
Impact Test Method	5
Retention Test.....	6
Performance Requirements	6
Reports	6
Labels and Warnings	7
DECEMBER, 2005 MODIFICATIONS/REVISIONS	12
JANUARY, 2006 MODIFICATIONS/REVISIONS	12
MARCH, 2006 MODIFICATIONS/REVISIONS.....	12
JUNE, 2006 MODIFICATIONS/REVISIONS	12
OCTOBER, 2006 MODIFICATIONS/REVISIONS	12
DECEMBER, 2006 MODIFICATIONS/REVISIONS	13
DECEMBER, 2006 MODIFICATIONS/REVISIONS	13
JANUARY, 2007 MODIFICATIONS/REVISIONS	13
May, 2009 MODIFICATIONS/REVISIONS	13

1. Scope

- 1.1. This standard specification establishes performance requirements for new soccer shin guards as supplied by manufacturers.
- 1.2. *This standard does not purport to address all of the safety problems, if any, associated with its use. It is the responsibility of the user of this standard to establish appropriate safety and health practices and determine the applicability of regulatory limitations prior to use.*

2. Referenced Documents

- 2.1. STANDARD DROP TEST METHOD AND EQUIPMENT USED IN EVALUATING THE PERFORMANCE CHARACTERISTICS OF PROTECTIVE HEADGEAR, NOCSAE DOC.001
- 2.2. ASTM 1446 - STANDARD TEST METHODS FOR EQUIPMENT AND PROCEDURES USED IN EVALUATING THE PERFORMANCE OF PROTECTIVE HEADGEAR.
- 2.3. prEN 13061 - PROTECTIVE CLOTHING – SHIN GUARDS FOR ASSOCIATION FOOTBALL PLAYERS- REQUIREMENTS AND TEST METHODS.
- 2.4. TECHNICAL REPORT J211A, "INSTRUMENTATION FOR IMPACT TESTS – SAE J211A". SOCIETY FOR AUTOMOTIVE ENGINEERS, INC. 1973 SAE HANDBOOK.

3. Terminology

- 3.1. Accessories: Those items that are required for the guard to comply with the retention requirements, but are not sold with the guard.
- 3.2. Ambient: Normal laboratory environment, 72° F, ± 5° F (22° C, ± 2° C).
- 3.3. Component: Any piece, part, or device that accompanies the guard or is part of the guard as offered for sale and may become separated (by design) from other shin guard components, or must be assembled or attached by the user.
- 3.4. Edge: That perimeter of the protective portion of the shin protector that lies on or beyond the area of required coverage.
- 3.5. Extent of protective coverage: The minimum size of a shin guard based upon Table 2 below for a specific athlete's height that must be met by the guard.
- 3.6. Identical Shin Guards: Identical shin guard refers to shin guards in the same model and size classification. Shin guard sets that include guards that are intended for use only on the left leg or right leg are considered identical so long as they are the same model and size classification.

- 3.7. Identical Sites: Identical sites refer to impact sites selected for testing on a series of three identical guards. If due to differences between guards intended for use only on the left leg or right leg of the wearer prevents meeting all of the requirements of section 10.1, then adjustments may be made to one guard such that the distance requirements of section 10.1 are met. The other two identical shin guards shall be impacted at identical sites.
- 3.8. Legible: May be easily read at a distance of not less than 18 inches by an individual with 20/20 corrected vision.
- 3.9. Perimeter of the protective portion of the guard: That portion of the guard/guard system that defines the area limits of the guards functional energy attenuating components. This definition specifically excludes the retention system or other components that may extend beyond the protective portion even though these components may provide some limited protection and may be key to the system function; they alone are not functional as the primary energy attenuation components.
- 3.10. Permanent (Label): A label, or similar markings, that cannot be readily (1), removed without leaving a trace of its previous existence (2), erased or (3), smudged to the point that it is illegible. If it **requires** chemical or mechanical means such as the use of solvents, abrasives, grinding, etc., to remove a label or marking, then that label or marking is acceptable. Required labels shall not be attached to any accessory.
- 3.11. Primary Protective Component: That component of the guard/system that is the primary energy attenuation device, without which the guard or system will not meet the impact requirements. If the guard has more than one component that could be called the Primary Protective Component under this definition that guard cannot be NOCSAE certified. If there are multiple components that alone, and separated from other components can meet the energy attenuation portion of these requirements then the most exterior of these components shall be the Primary Protective Component. If the guard does not have separate components as defined above then the entire shin guard shall be the primary protective component.
- 3.12. Shin: The front part of the leg from the knee to the ankle. More specifically, the anterior portion of the tibia below the attachment of the patellar ligament and above the attachments of the lower ligaments connector point on the anterior portion of the medial malleolus.
- 3.13. Shin guard: A protective device/system placed over the shin in an effort to reduce injury to the shin. Some are homogenous while some are component systems that may even be "assembled" by the end user. Some may require accessories for compliance with the retention performance section(s) of this standard. Any item that affects any other portion of the guard's performance in the test shall be deemed a component and must be provided with the guard as offered for sale.

4. Samples for Testing

- 4.1. Shin guard sets new, and as offered for sale to the public, shall be submitted for this test.
- 4.2. At least three sets of each size of a shin guard model or if a model includes only one size shin guard, a minimum of three sets.
- 4.3. Shin guard sets used for testing must be selected in a random manner.
- 4.4. A sufficient number of accessories (if needed) shall be provided to the test laboratory to facilitate the fitting of the guard per the fitting instructions.

5. Sample Size.

- 5.1. A statistically relevant sample must be tested¹.

6. Certification.

- 6.1. See section 6 of NOCSAE DOC 001 for certification requirements.

7. Test Equipment

- 7.1. A conical leg anvil (see Figure 1 below) made from steel used to secure the shin guard during impact testing connected to a heavy base [55 lbs (25 kg) minimum] with an adjustable mounting that will allow impacts to be delivered to any point of the shin guard. This assembly shall be mounted to a substantial base plate of at least 330 lbs (150 kg).
- 7.2. The spherical impactor as specified in ASTM 1446 shall be attached to the free fall drop assembly carriage free to slide on a vertical guide. The guide assembly shall not weigh more than 2.43 lbs (1100 g). The total weight of the guide assembly and spherical impactor shall be 11.02 lbs \pm 0.22 (5000 g \pm 100).
- 7.3. A linear accelerometer is mounted at the center of gravity of the spherical impactor with the sensitive axis aligned to within 5° of the vertical when the spherical impactor is in the impact position. This transducer shall be capable of withstanding a shock of (1000 g) without damage and shall have a frequency response (variation \pm 1.5 %) over the range from 5 to 900 Hz.
- 7.4. The impact shall be recorded on a storage oscilloscope with at least a 50 kHz bandwidth, or any digital system meeting or exceeding these requirements. Acceleration data channel and filtering shall comply with SAE Recommended Practice J211, CFC 1000.

¹ For guidance on what is an acceptable sample size, interested parties can refer to Military Standard 105-E Standard Series, ISO 9000 Standard Series or ANSI/ASQL Standard Series.

8. Marking the Impact Area

- 8.1. Compute the values for lines 1,2 and 3 and radii 4 and 5 in Table 2 using the manufactures stated value for the height of the tallest wearer.
- 8.2. Mark the centerline of the guard.
- 8.3. Using the value for line 1 computed above, center this line along the centerline of the guard; mark the top and bottom points of this line on the guard's centerline.
- 8.4. Mark a line equal to the value of line 2 perpendicular to and passing through the top endpoint of line 1, mark line 3 parallel to line 2 and passing through the lowest most point of line 1, lines 2 and 3 shall have their center point on the guards centerline.
- 8.5. Using 25% of the computed value for line 2, mark this distance along line 2 to the right and left of the centerline.
- 8.6. Using 25% of the computed value for line 3, mark this distance along line 3 to the right and left of the centerline.
- 8.7. Mark a line between the two points (marked in step 8.5 and 8.6 above) to the right of the centerline. Mark a line between the two points (marked in step 8.5 and 8.6 above) between the two points to the left of the centerline.
- 8.8. The area encompassing the lines drawn in steps 8.4 and 8.7 defines the central portion of the impact area of the guard.
- 8.9. Mark a line between the endpoints of line 2 and 3 to the right of the centerline and again between the endpoints of line 2 and 3 to the left of the centerline.
- 8.10. Using the endpoints of line 2 as the center of radius, mark a radius the value of radius 4 on the right and left sides of the centerline at the top of the of the guard insuring that the radii created cross line 2 and the lines created in 8.9.
- 8.11. Using the point created by the intersection of the radii created in 8.10 and the lines created in 8.9 as the center of radius, mark a radius of value radius 4 on the right and left sides insuring the radii created cross the lines created in 8.7.
- 8.12. Using the point created by the intersection of the radii created in 8.10 and line 2 as the center of radius, mark a radius of value radius 4 on the right and left sides, insuring the radii created cross the lines created in 8.7.
- 8.13. Using the point created by the intersection of the radii created in 8.11 and 8.12 as the center of radius. Mark radii 4 on the right and left sides. These radii serve as the radii of curvature for the right and left corners.

- 8.14. Repeat the steps 8.10 through 8.13 for the bottom of the guard using line 3 instead of line 2 as the reference and substituting the value of radius 5 for the value of radius 4.
- 8.15. The area encompassing the lines and radii drawn in steps 8.9 through 8.14 excluding the central impact area defines the lateral portion of the impact area of the guard.

9. Extent of Protective Coverage

- 9.1. Each size of shin guard submitted shall be marked per section 8 to determine its extent of protective coverage. The minimum protective coverage area shall conform to the dimensions specified in Figure 2 and Table 2 below.

10. Impact Test Method

- 10.1. Three identical shin guards shall each be impacted at three identical sites, with three impacts at each site. Time between successive impacts shall be $75 \text{ s} \pm 15$. The center of any impact series shall not be less than 1.97 inches (50 mm) from any previous impact series nor closer to any edge than 0.59 inches (15 mm). Impact locations shall be selected to include any apparent weak points but must lie within the area of coverage. At least one impact site shall be in the central portion of the guard, and at least one impact a site shall be within the lateral portion of the guard. If guards are labeled left and right at least one of each side shall be tested.

NOTE: In the event that the extent of protective coverage lies within the 15mm “offset” from the edge the impact center must still be 15mm from the edge. However in any case where the test area was limited by the 15 mm offset the guards’ protective properties must extend to the edge of the extent of protective coverage.

- 10.2. Each shin guard shall be fastened onto the leg anvil in such a way as to limit movement during impacts. The leg anvil is positioned so that the striking face of the spherical impactor impacts the surface of the shin guard.
- 10.3. The spherical impactor is raised above the shin guard and allowed to fall striking the shin guard at the velocity specified in table 1 below for each location chosen. Velocities shall be measured within 1 inch (25.4mm) of the impact.

Table 1
Impact Velocities

Central Portion Ft/Sec (m/s)	Lateral Portion Ft/Sec (m/s)
5.67 ± 0.17 (1.73 ± 0.05)	2.46 ± 0.07 (0.75 ± 0.02)

10.4. The impact location, resultant peak g and velocity shall be recorded for each impact.

11. Retention Test

11.1. Attach the shin guard onto the retention test leg anvil (see figure 3) following the manufacturer's fitting instructions.

11.2. Using a spring balance, force gauge or other suitable device, apply a test force of 15 ± 2 N tangential to the surface of the shin guard. The force can be applied in any direction except in the direction corresponding to the downward direction when the shin guard is worn as in play according to the manufacturer's fitting instructions. This force is applied for not less than 30 s nor more than 45 s.

11.3. The displacement of the shin guard is measured when the force is removed and recorded.

12. Performance Requirements

12.1. When tested according to Section 10, the mean peak g of the three impacts delivered to the same impact site shall not exceed 200 g. No single impact shall exceed 225 g.

12.2. When tested according to Section 11, on release of the force, the displacement of the shin guard from its initial position shall be less than 0.75 inches (19 mm).

13. Reports

13.1. Maintain complete test records for all testing. The records can be stored on paper, electronically or photographically. The test report shall contain the following information.

13.1.1. Name and location of the test laboratory.

13.1.2. Name of Laboratory Technician.

13.1.3. Model and size of each shin guard tested, name of manufacturer and date of manufacture.

13.1.4. Observed laboratory temperatures.

13.1.5. Impact results incorporating the impact locations, drop heights, and Peak Acceleration for each impact.

13.1.6. Retention test results. List the displacement, direction of applied force and time of applied force if noncompliant.

14. Labels and Warnings

14.1. Each shin guard's primary protective component shall be permanently and legibly labeled or marked in a manner such that the following information can be easily read and is not obscured in any manner.

14.1.1. Name of Manufacturer or a Logo or recognizable mark that is registered and/or trademarked to the manufacturer.

14.1.2. Model Designation.

14.1.3. Size, including the height in inches of the tallest wearer for which the size is intended. This size information must be accessible, without removal of the guard, to the referee for inspection

14.1.4. Month and Year of Manufacture.

14.1.5. Notice that indicates additional information is available to the wearer. Such additional information may be on the packaging, insert or removable tag.

14.1.6. A permanent, exact replica of this seal must appear legibly on the exterior top one third of the shin guard's primary protective component so as to be accessible, without removal of the guard, to the referee for inspection. If the label is stitched to the guard it must be positioned/positionable such that this information is visible and legible (not upside down)



NOTE: You must have an executed, valid license agreement with NOCSAE to use any of the NOCSAE logos at any time. NOCSAE, the NOCSAE seals/logos, and the National Operating Committee on Standards for Athletic Equipment are registered marks and the exclusive property of the Committee. Use of the marks in any manner is prohibited without prior written permission of the NOCSAE Board of Directors. In place of manufacturer certifies the manufacturer may use it's own name i.e., xyz company certifies "MEETS NOCSAE STANDARD" This seal maybe scaled so long that it remains legible.

14.2. Packaging and/or instructional literature for soccer shin guards shall be permanently and legibly marked in a manner such that the following information can be easily read.

14.2.1. Information that warns the user that the shin guard can be damaged by contact with common substances (for example, certain solvents, cleaners, etc.) and that this damage may or may not be visible to the user. This information should also list any recommended cleaning agents or procedures, or both.

14.2.2. Information that warns the user that for maximum performance the manufacturers fitting instructions must be followed.

14.2.3. Language that effectively communicates to the purchaser and user the following information, using the same or similar language:

WARNING

DO NOT USE THIS SHIN GUARD IF THE SHELL IS CRACKED OR DEFORMED. NO SHIN GUARD CAN PROTECT AGAINST ALL FORSEEABLE IMPACTS. SEVERE INJURY MAY OCCUR TO YOU DESPITE USING THIS GUARD. DANGEROUS PLAY IS AGAINST THE RULES OF SOCCER.

14.2.4. Fitting and positioning instructions or graphics showing proper fit and position, including proper use/assembly of all components or accessories.

This standard is subject to revision at any time by the responsible technical authority and must be reviewed every five years and if not revised either reapproved or withdrawn. Your comments are invited either for revision, modification or creation of additional standards and should be addressed to NOCSAE's Executive Director. Check the web at www.nocsae.org to obtain the latest version of a standard.

This standard is copyrighted by NOCSAE 11020 King Street, Suite 215 Overland Park, Kansas 66210 USA. Copies may be obtained from the NOCSAE web site at www.nocsae.org

LEG ANVIL

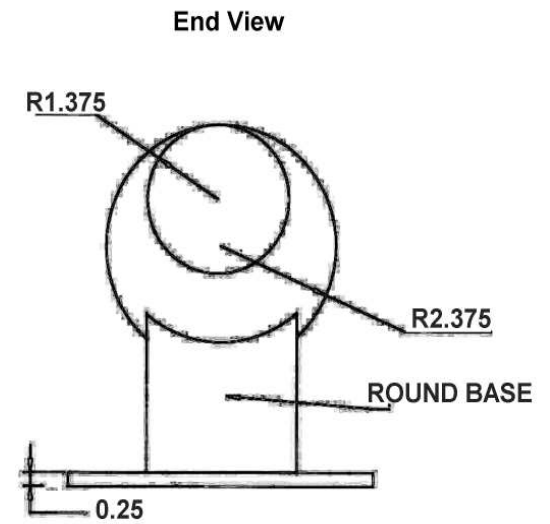
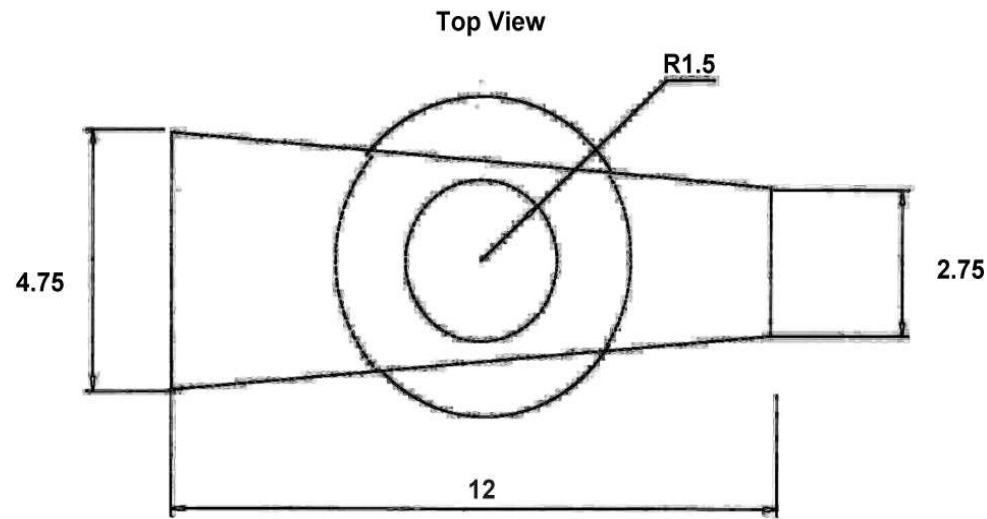

Tolerances = +/- 1/8" Dimensions in Inches

Figure 1

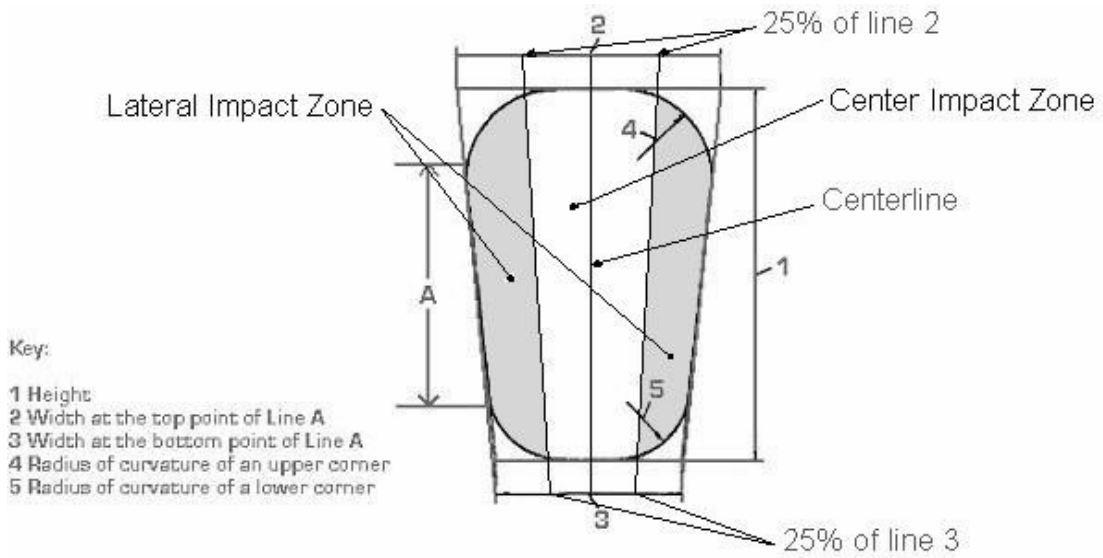
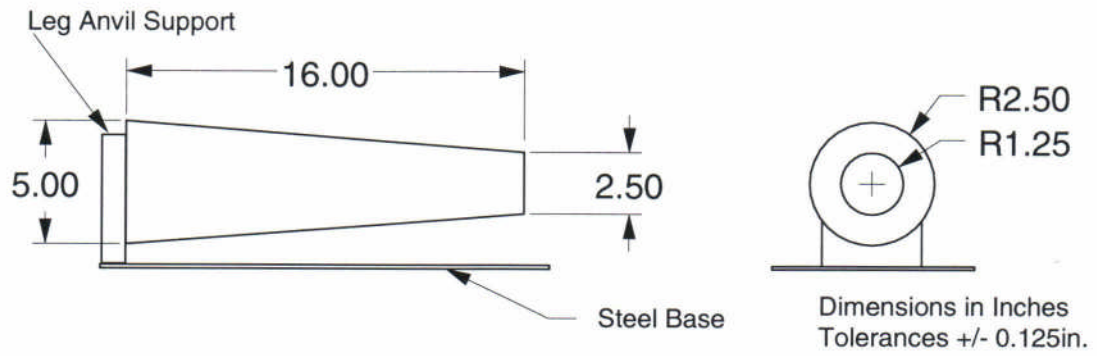

Figure 2

Table 2

	Line 1	Line 2	Line 3	Radius 4	Radius 5
Dimension expressed as the percentage of the tallest wear's height	9.5	6.4	4.5	2.2	0.9

Retention Leg Anvil



Surface roughness of Retention Anvil shall be no finer than a 63st and no rougher than a 125st.

Figure 3

DECEMBER, 2005 MODIFICATIONS/REVISIONS

- Modified terminology describing protective coverage.
- Added section 7 description of Marking the Impact Area.
- Modified Labeling Requirements.
- Modified nomenclature for levels of guards certified and descriptions of levels of play.
- Add tolerance to Leg anvil dimensions.

JANUARY, 2006 MODIFICATIONS/REVISIONS

- Changed title nomenclature.
- Added NOCSAE DOC 001 as referenced document.
- **Revision** - Deleted Shin Guard Level reference throughout document.
- Added certification reference.

MARCH, 2006 MODIFICATIONS/REVISIONS

- Updated section 8 numbering

JUNE, 2006 MODIFICATIONS/REVISIONS

- Updated section 12 numbering
- Modified and added report requirements in section 13
- Corrected typographical error in section 14

OCTOBER, 2006 MODIFICATIONS/REVISIONS

- Added definition of Identical Shin Guard and Identical Sites.

- Modified section 4 to specify sets of shin guards is required for this test.

DECEMBER, 2006 MODIFICATIONS/REVISIONS

- Clarified and added labeling requirements
- Changed section 7.4 bandwidth from 500kHz to 50 kHz
- Added language to address left and right side guards in section 10.1
- Added section 3.7 definitions
- Clarified section 3.10 definition
- Added note to section 10.1 for clarity

JANUARY, 2007 MODIFICATIONS/REVISIONS

- Added definition of Accessories, Components, and Primary Protective Component
- Clarified definition of Shin Guard
- Clarified section 4 for submittal of accessories for testing
- Clarified section 14.1, 14.1.3, 14.1.6 and 14.2.4 Labeling and Warnings

MAY, 2009 MODIFICATIONS/REVISIONS

- Modified section 11.1 to add use of retention anvil, Added figure 3, Retention Leg Anvil.
- Modified the name of the document to be consistent with NOCSAE document nomenclature