

**STANDARD TEST METHOD AND
EQUIPMENT USED IN EVALUATING THE
PERFORMANCE CHARACTERISTICS OF
PROTECTIVE HEADGEAR/EQUIPMENT**

NOCSAE DOC (ND) 001- 11m11

Prepared By



**NATIONAL OPERATING COMMITTEE
ON STANDARDS FOR ATHLETIC EQUIPMENT**

Revised: January 2011
Effective no later than January 2012

TABLE OF CONTENTS

Preface	1
Scope	3
Referenced Documents	3
Terminology	4
Ambient	4
Basic Plane.....	4
Bill.....	4
Chin Strap.....	4
Common Substances	4
Coronal: Plane.....	4
Crack	4
Critical sizes.....	5
Dycal.....	5
Edge	5
Eye Protector.....	5
Face.....	5
Faceguard	5
Figure	5
Hardware	5
Head.....	5
Headform.....	5
Headgear.....	5
Helmet	5
Impact Area	6
Intact.....	6
Legible	6
MEP.....	6
Midsagittal (Median) Plane	6
Neck Strap.....	6
Nose Gauge	6
Permanent (component).....	6
Permanent (Label).....	6
Primary Retention.....	6
Reference Plane.....	6
Retention System	7
Severity Index.....	7
Shell.....	7
Signal Conditioner	7
Signal Word.....	8
Triaxial Accelerometer.....	8
Significance and Use	8
Summary of Test Method.....	9
Certification.....	10
Construction.....	10
Labeling & Instructions.....	10
Samples for Testing.....	12
Sample Size.....	12
Conditioning Environments	12
Ambient Temperature.....	12

High Temperature	12
Testing Environment.....	13
Test Headforms	13
Reports	13
Impact Test Instruments and Equipment.....	14
Instrument Calibration	14
Headform Calibration	15
System Check.....	15
Impact Attenuation Tests	15
Helmet Positioning/Fit	16
APPENDIX.....	18
Specifications	18
Figure 3 TABLE 2.....	20
MAY, 1998 MODIFICATIONS/REVISIONS.....	22
MAY, 2000 MODIFICATIONS/REVISIONS.....	22
JUNE, 2001 MODIFICATIONS/REVISIONS	22
JANUARY, 2002 MODIFICATIONS/REVISIONS.....	22
JANUARY, 2004 MODIFICATIONS/REVISIONS	23
MARCH, 2004 MODIFICATIONS/REVISIONS	23
AUGUST, 2004 MODIFICATIONS/REVISIONS.....	23
FEBRUARY, 2005 MODIFICATIONS/REVISIONS	23
DECEMBER, 2005 MODIFICATIONS/REVISIONS	23
APRIL, 2006 MODIFICATIONS/REVISIONS	24
DECEMBER, 2006 MODIFICATIONS/REVISIONS	24
JANUARY, 2007 MODIFICATIONS/REVISIONS.....	24
JUNE, 2007 MODIFICATIONS/REVISIONS	24
JANUARY, 2008 MODIFICATIONS/REVISIONS.....	24
MAY, 2008 MODIFICATIONS/REVISIONS.....	24
AUGUST, 2008 MODIFICATIONS/REVISIONS.....	24
DECEMBER, 2008 MODIFICATIONS/REVISIONS	25
MAY, 2010 MODIFICATIONS/REVISIONS.....	25
JANUARY, 2011 MODIFICATIONS/REVISIONS.....	25

PREFACE

In an effort to reduce the severity and number of head injuries in certain organized sports, the National Operating Committee on Standards for Athletic Equipment (NOCSAE®)¹ has developed methods and performance requirements for testing protective headgear/equipment. It is believed that fewer head injuries will be incurred provided the following conditions are met:

- a. Manufacturer adherence to the certification of new headgear/equipment utilizing the appropriate NOCSAE standards.
- b. Manufacturer implementation of an effective Quality Assurance Program.
- c. Consumer adherence to a program of periodically having used headgear inspected and re-tested in accordance with the appropriate NOCSAE standards.
- d. Re-certifiers adherence to the testing of reconditioned headgear in accordance with the appropriate NOCSAE standards and procedural guides.
- e. Re-certifier implementation of an effective Quality Assurance Program.
- f. Participation in ongoing Round Robin system verification of all laboratories performing testing to NOCSAE standards.

This standard test method specifies basic performance requirements, methods and equipment used for testing protective headgear/equipment. Individual performance standards (standard specifications) will use this method and equipment. Impact velocities, pass/fail criteria and other performance requirements will be specified in individual standard specifications, tailored to the needs of a particular activity.

The methods of test and performance required are based on research initiated in 1971 at Wayne State University, Department of Neurosurgery Biomechanics Laboratory under the direction of Dr. Voight R. Hodgson and continues today at the Sports Biomechanics Laboratory of the University of Tennessee. This test method incorporates many aspects of other recognized headgear performance standards. They draw from work done by others where appropriate for this test method. These standards may be referenced.

NOCSAE recognizes the difficulty of formulating a laboratory standard to reduce head injury in an environment in which the injury incidence is relatively low. Further, many injury mechanisms remain unknown, and no tolerable index is available for hemorrhagic injuries or subdural hematomas that are a primary cause of death and permanent injury in certain organized sports. The NOCSAE drop test method defines impact limits for linear acceleration. The Standards are a recommended procedure for headgear/equipment manufacturers and re-certifiers, which if followed, should aid in the reduction of future injuries.

¹ The National Operating Committee on Standards for Athletic Equipment was established in 1969. Current membership: the American College Health Association, the American College of Sports Medicine, American Orthopedic Society for Sports Medicine, the Athletic Equipment Managers Association, the American College Football Coaches Association, the National Association of Secondary School Principals, the National Athletic Equipment Reconditioners Association, the National Athletic Trainers Association and the Sporting Goods Manufacturers Association.

Since the testing requirements and certification of manufacturer's models are based on new products, it is recommended that the consumer maintain a Recertification Program.

It is recognized that interested parties should continuously review NOCSAE standards in the light of progress in injury reporting, research and manufacturing techniques and suggestions for improvement. In instances where changes affect any of the following critical test parameters, the effective date of the revised Standard will be the time of issuance plus 12 months.

- a. Headform characteristics
- b. Drop heights/velocities
- c. Environmental conditions
- d. Anvil and/or impact surface characteristics
- e. Severity Index (SI) Limits, Pass/Fail Criteria
- f. Number of impacts
- g. Impact location
- h. Instrumentation

Revised NOCSAE Standards must be in writing and the year of revision adopted as the suffix of the Document number. All NOCSAE standards that have not been revised or modified for a period of five (5) years shall be referred to the board for action. The board shall decide to maintain the standard in its current form, revise the standard or withdraw the standard within one year. Withdrawn standards are not supported and should not be referenced by any governing body.

Minor changes to a NOCSAE Standard are identified as being a "modification." Modifications are to be adhered to at the time of the subsequent issuance of that document. No change to the Document number is made for a modification however the month and year of the modification is noted on the cover page.

NOCSAE publishes standards but does not conduct surveillance to assure compliance to Standards. This is the sole responsibility of firms that affix the NOCSAE seal of certification to headgear/equipment.

Manufactures must be aware that with any mechanical system there are tolerances (i.e. the stem and rotator angles have a $\pm 1^\circ$ tolerance) that may affect the outcome of the tests. For example, with the tolerance of the stem and rotator taken into account, some random locations may be deemed outside of the impact area in some labs on some helmets while inside the impact area in others. Therefore, it is recommended that manufactures take necessary steps to be certain that products tested with consideration to all tolerances remain in compliance with NOCSAE standards. If an impact location is determined to be within the impact area on a mechanical system that is within the allowable tolerances, then that impact location is considered to be a valid impact site for all NOCSAE systems.

NOCSAE does not approve, disapprove, certify or recertify athletic equipment of any kind.

Scope

- 1.1 This standard test method describes laboratory equipment and basic requirements pertinent to drop testing protective headgear/equipment. Deviations, additions or both, to this test method will be specified, as required, in individual standard performance specifications.
- 1.2 This standard test method is limited to use with products associated with specific NOCSAE standards.
- 1.3 *This standard does not purport to address all of the safety problems, if any, associated with its use. It is the responsibility of the user of this standard to establish appropriate safety and health practices and determine the applicability of regulatory limitations prior to use.*

2 Referenced/Historical Documents

- 2.1 Gadd, C.W. (600793): Use of a Weighted - Impulse Criterion for Estimating Injury Hazard, Proceedings of the Tenth Stapp Car Crash Conference, November 8-9, 1966. SAE, Incorporated, Two Pennsylvania Plaza, New York, New York 10001.
- 2.2 Prasad, P. and Mertz, H.J.: "The Position of the United States Delegation to the ISO Working Group 6 on the Use of HIC in the Automotive Environment".
- 2.3 Churchill, E., et al.: Anthropometry Research Project Yellow Springs, Ohio, December 1971; Anthropometry of the U.S. Army Aviators - 1970; National Technical Information Service; U.S. Department of Commerce; 5285 Port Ridge, Springfield, VA 22151; December 1971.
- 2.4 Leslie G. Farkas, M.D., C.Sc., D.Sc., FRCS (C) Assoc. Prof., Dept. of Surgery University of Toronto: "Anthropometry of the Head and Face" 1st Edition, Raven Press, NY
- 2.5 Leslie G. Farkas, M.D., C.Sc., D.Sc., FRCS (C) Assoc. Prof., Dept. of Surgery University of Toronto: "Anthropometry of the Head and Face" 2nd Edition, Raven Press, NY
- 2.6 S. J. Ulijaszek & C. G. N. Mascie: Anthropometry: The individual and the Population Cambridge Studies in Biological Anthropology – Taylor Department of Biological Anthropology University of Cambridge, Cambridge, UK
- 2.7 J. A. Roebuck, JR: Anthropometric Methods: Designing To Fit The Human Body - Human Factors and Ergonomics Society PO Box 1369 Santa Monica, CA 90406
- 2.8 Claus. W. D., et al.: Development of Headform for Sizing Infantry Helmets; Technical Report 75-23 CAMEL Project Ref.LT662713Dj90 Series CEMEL-131; Clothing, Equipment, and Materials Engineering Laboratories, Natwick, MA 01760.

- 2.9 Additional data used in headform development.
 - 2.9.1 Anthropometry of the Head, Neck and Face MIT Press
 - 2.9.2 SAE publications on Human Anthropometry
 - 2.9.3 Halstead Study Of Facial And Cranial Features In Athletes, 1987 Unpublished
 - 2.9.4 Reicho data is from that individual's ongoing, as yet unpublished, data on eye and face anthropometrics.
- 2.10 Technical Report J211a, "Instrumentation for Impact Tests - SAE J211a". Society for Automotive Engineers, Inc. 1973 SAE Handbook.
- 2.11 Technical Report "Recommendations For Mechanical Test System Revisions." Submitted to NOCSAE by Halstead, et al, 1994.
- 2.12 Military Standard Series 105
- 2.13 ISO 9000 Standard Series.
- 2.14 ANSI/ASQC Q 90 Standard Series.
- 2.15 ASTM F 1446

3 Terminology

Descriptions of Terms Specific to This Standard -

- 3.1 Ambient: Normal laboratory environment, 72° F, ± 5° F (22° C, ± 2° C).
- 3.2 Basic Plane (Frankfort Plane): An anatomical plane that includes the superior rims of the auditory meatuses (the upper edges of the external openings of the ears) and the notches of the inferior orbital ridges (the bottom edges of the eye sockets).
- 3.3 Bill: See visor
- 3.4 Chin Strap: See Retention System
- 3.5 Common Substances: Household and other readily available materials that are likely to come in contact with headgear / equipment either intentionally (i.e. attempts to clean or polish) or unintentionally via transfer or proximity to the headgear / equipment (Hair treatments, bug spray / lotions, sunscreen, etc.).
- 3.6 Coronal: Plane: An anatomical plane perpendicular to both the basic plane and the midsagittal plane and containing the midpoint of a line connecting the superior rims of the right and left auditory meatuses.
- 3.7 Crack: A structural discontinuity which cannot support a load normal to its surface without the creation of new surface area.

- 3.8 Critical sizes: Critical sizes are defined as follows:
- 3.8.1 The helmet's "Stetson" size, typically denoted as a numeric value that is the circumference divided by pi, i.e. $71/4$ that corresponds to the correct headform's "Stetson" size.
 - 3.8.2 The thinnest padding configuration for a particular helmet shell on the largest headform designated for the selling size range for that particular shell.

Note: In the event that the largest size of a model is too small to fit the smallest headform, data and conclusions from a substantially similar model may be used to certify the smaller model. In the event the largest size of a model is too large for the largest headform the helmet must still be tested and may be shimmed to approximate proper fit for impact testing.
- 3.9 Dycal: A dynamic signal generator used to calibrate the Severity Index computation system using only a digital voltmeter.
- 3.10 Edge: That portion of a headgear's lower perimeter that lies on or below the theoretical lines which define the specified area of impact.
- 3.11 Eye Protector: A device that may be attached to a headgear and is designed to offer limited protection to the ocular area of the face.
- 3.12 Face: That portion of the head that is anterior to a plane paralleling the Coronal plane, said plane bisects the posterior most portion of the external canthus.
- 3.13 Faceguard: Headgear that when correctly fitted to a helmet is designed to offer protection to that portion of the wearer's face, not covered by the helmet, which is covered by the faceguard as worn. Also known as the face protector.
- 3.14 Figure: Illustrations, representations and/or photographs that are intended as an aid to understanding the test method, performance criteria or procedures. Figures are not typically definitive and in any case, where the written text is, or seems in conflict, with a figure the text shall be deemed as the standard.
- 3.15 Hardware: Any device, arrangement, or component (not otherwise defined) that facilitates an object to become attached to headgear, including those systems that are integral to or apart from any other headgear component.
- 3.16 Head: That portion of the body that is above the neck and specifically does not include any part of any vertebral bodies (cervical or any other sections of the spine).
- 3.17 Headform (NOCSAE): An instrumented model human head designed to fit the carriage assembly and possessing a high bio-fidelity.
- 3.18 Headgear: Any device placed on the head, or attached to any other appliance placed on the head, to provide protection to the head and/or face of the wearer.
- 3.19 Helmet (See Headgear): A protective device worn on the head in an effort to reduce or minimize injury to that portion of the head which is within the specified area of coverage while participating in various activities where risk of head injury is recognized.

- 3.20 Impact Area: The area above the basic plane aft of a specified point anterior to the coronal plane and above the reference plane forward of that same point unless otherwise specified in an individual standard performance specification (see Fig. 2).
- 3.21 Intact: The component or system is considered intact, if it can withstand a repeat test at the same magnitude and location that raised the question as to whether the component or system remained intact. The repeat test must render results that meet the standard requirements in all aspects. Intact does not mean undamaged or unblemished but does mean ready to perform the intended function of the component or system in question.
- 3.22 Legible: May be easily read at a distance of not less than 18 inches by an individual with 20/20 corrected vision.
- 3.23 MEP- Modular Elastomer Programmer: A cylindrical shaped pad used as the impact surface.
- 3.24 Midsagittal (Median) Plane: An anatomical plane perpendicular to the basic plane and containing the midpoint of the line connecting the notches of the right and left inferior orbital ridges, and the midpoint of the line connecting the superior rims of the right and left auditory meatus.
- 3.25 Model: A family or design of headgear/equipment typically available in more than one size that is intended to be identical in every way, except for size. While it may be substantially similar to some other model, it is not intended to be identical to it. Component parts must be the same except for geometries needed to create different sizes. Energy management systems must be of the same materials and construction. Graphical treatments and colors may be variable. If only available in one size or size range, the design must be unique in some respect and therefore is not part of some other family or design (model).
- 3.26 Neck Strap: See Retention System
- 3.27 Nose Gauge: A device used to determine that a helmet is consistently positioned on the test headform with respect to the headform's nose.
- 3.28 Permanent (component) – A product component that is not intended to be removed and replaced by a user or a recertifier.
- 3.29 Permanent (Label/Marking) – A label, or similar marking, that cannot be readily (1), removed without leaving a trace of its previous existence (2), erased or (3), smudged to the point that it is illegible. If it **requires** chemical or mechanical means such as the use of solvents, abrasives, grinding, etc., to remove a label or marking, then that label or marking is acceptable.
- 3.30 Primary Retention: See Retention System
- 3.31 Reference Plane: A plane marked on the headforms at a specified distance above and parallel to the basic plane.

Note - See Table 1 and Figure 1 for other anatomical reference points on NOCSAE headforms.

- 3.32 Retention System: The complete assembly that secures the helmet in a stable position on the wearer's head.
- 3.32.1 Chin Strap: A component of the helmet retention system which, when properly adjusted, rests on or encompasses the anterior and inferior most portions of the user's face.
- 3.32.2 Neck Strap: A component of the helmet retention system which, when properly adjusted, rests beneath the user's mandible.
- 3.32.3 Primary Retention: If the helmet is equipped with both a chinstrap and a neck strap, the neck strap is the component to be tested.
- 3.33 Severity Index: A measure of the severity of impact with respect to the instantaneous acceleration experienced by the headform as it is impacted. Acceptable Severity Index (SI) levels measured during impact cannot exceed the limit specified in the individual standard performance specification.

The Severity Index is defined as:

$$SI = \int_0^T A^{2.5} dt$$

Where: A is the instantaneous resultant acceleration expressed as a multiple of g (acceleration of gravity); dt are the time increments in seconds; and the integration is carried out over the essential duration (T) of the acceleration pulse.

For purposes of electronic data gathering, the integration as called for in this formula must begin after the system triggers but before the initial signal rises above 4 g's. The integration must then end when the signal falls below 4 g's, after it has peaked.

- 3.34 Shell: The exterior casing of a helmet. Normally the rigid structural component of a helmet.
- 3.35 Shimming: Refers only to the situation where a critical size is too large for the largest headform. A helmet too large can be shimmed to approximate fit so long as the shim material is of a mechanical property of low density and compression when compared to the primary energy management system used in the helmet. Shims must be placed in such a way that no part of the shim material is involved in the direct, initial impact. The helmet shall be shimmed so that the impacted area is fit to the head as intended for that area if the helmet were a proper fit to the headform. Additional time of up to three extra minutes shall be allowed for the onset of testing for conditioned samples to facilitate shim placement.
- 3.36 Signal Conditioner: A module of the Severity Index computation system that conditions the input for the Vector Analyzer and Severity Index computation system. It will excite and condition the signals from a triaxial accelerometer of a specific type, or accept ± 5 volts of maximum input directly.

Note - PC based, or other digital signal processing systems, if used, may replace the dycal and/or signal conditioner. In those instances, system compatibility and capabilities must be demonstrable.

- 3.37 Signal Word: A particular word or symbol on some types of labels that is meant to draw the attention of, and has meaning to, the reader and/or user of the product to which the label is affixed; or calls attention to that label. Examples would be words like **WARNING**, **DANGER**, **CAUTION**, **STOP**, or the like.
- 3.38 Similar Model: Refers only to the situation that prevents a small size helmet from being tested because it is too small for the smallest headform and there is no larger size of the same model available for testing. Similar model shall mean a model that, except for size, has geometry substantially the same as a larger tested size and has an energy management system that is of the same density, compression resistance and thickness tolerances as on the larger size tested model. If the parameters stated above are not the appropriate measures for a particular type of energy management system, it shall be incumbent on the manufacturer to prove the energy management system on the similar model is the same in function as the larger tested model. Any fitting system and the retention system must also be substantially the same as the larger tested model. If there is not a testable size of a larger model that is substantially similar to the smaller model, the smaller un-testable helmet model may not be certified and shall not bear the NOCSAE logo.
- 3.39 Triaxial Accelerometer: A small piezoelectric acceleration transducer with three (3) axes, designed specifically for vibration measurement in three (3) orthogonal axes. The accelerometer must be mounted at the center of gravity of the test headform with a sensitive axis aligned to within 5 degrees of the vertical when the headform is in the top impact position. The acceleration data channel complies with the SAE Recommended Practice J211a JUN 80-channel class 1000 filter with the cutoff at 1000 Hz (a low pass filter having a 4-pole Butterworth transfer function and a corner frequency of 1000 Hz meets this requirement). Digital filtering at 1000 Hz can be substituted. (Note: Some other helmet test systems specify the same class filter with a 1650 Hz roll off)
- 3.40 Visor: An extension of the shell that may be an added component or an integral portion of the shell that extends forward from the front surface in such a way so as to shield the wearer's eyes from the sun. The visor may have attachment points for face protection mounting. The visor is limited to that part of the device that is not in contact with the shell. If the visor is an integral portion of the shell (i.e., shell and visor is molded as one piece), then the visor is that portion that extends into space outward from the helmet's edge.

4 Significance and Use

- 4.1 The purpose of this test method is to provide reliable and repeatable measurements for the evaluation of various types of protective headgear/equipment. This test method is based on pass/fail criteria only. A passing headgear/equipment is able to withstand the impact at an acceptable SI and meets all other requirements of the Performance Specifications when tested in accordance with this test method.
- 4.2 This test method must be used in conjunction with the specific individual standard performance specifications relative to a specific activity.

5 Summary of Test Method

- 5.1 A headgear is positioned on a headform and then dropped in order to achieve an accepted free fall velocity. At impact, the instantaneous resultant acceleration is measured by the triaxial accelerometer and the Severity Index is calculated.
- 5.2 The impact velocities specified in the individual performance standards for impact testing shall be measured during the last 1.5 in. (40 mm) of free fall for each test.
- 5.3 If an impact that exceeds the specified velocity range results in a test exceeding the performance criterion, the testing for the sample shall be declared inconclusive and must be repeated.
- 5.4 The impact velocities specified in the individual performance standards are based on specific velocities and not drop heights. Typical velocity measurement systems record the average velocity of the drop system for a distance just prior to impact which may introduce over a 1% difference from the actual velocity (higher velocities will have less error than lower velocities). To attain the proper velocity for an impact, it is likely that the drop height will need to be adjusted to compensate for both friction and velocity measurement error. If height adjustments made to attain the proper velocity for an impact account for more than 10% of the total drop height the drop system should be evaluated for repair.

6 Certification

- 6.1 NOCSAE publishes standards but does not conduct surveillance to assure compliance to standards. It is the sole responsibility of firms that manufacture or recertify protective products to certify that all requirements of these standards are met, including ongoing statistically relevant QC protocols.
 - 6.1.1 Firms utilizing the NOCSAE logo to originally (prior to the first time such product/model is offered for sale) certify products, must submit documentation in the form of a test report from an independent A2LA accredited ISO 17025 certified laboratory, with the appropriate scope. (Other independent forms of certification to ISO 17025 may be acceptable in place of A2LA accreditation ¹)
 - 6.1.2 In addition, at least annually, each firm that originally certified a product as compliant shall provide proof of ongoing compliance in the form of a laboratory report from an A2LA accredited ISO 17025 certified laboratory with the appropriate scope. (Other independent forms of certification to ISO 17025 may be acceptable in place of A2LA accreditation ¹) The number of samples submitted shall be equal to the number required in the appropriate standard section titled "Sample Size".
 - 6.1.3 These reports are limited to the product performance and markings, warnings and other literature.

¹ The decision to accept other than A2LA proof of compliance with ISO 17025 shall be made by the executive director or his/her appointee.

- 6.2 In the case of product that has been discontinued, is no longer being manufactured but is still available for sale, annual proof of certification from an independent accredited laboratory will not be required if either condition below is true:
- 6.2.1 The product has been certified in the past, is the subject of a past independent test demonstrating compliance and no product has been produced since that last independent certification test.
- 6.2.2 The discontinued product was last produced prior to June 2008; in such case the product shall be exempt from the requirements for independent demonstration of compliance.

7 Construction

- 7.1 General: Headgear shall be constructed to reduce the acceleration of the wearer's head, and to remain on the wearer's head, during impact. Optional devices fitted to the headgear/equipment shall be designed so that they are unlikely to cause injury during use. For example: Wire face protectors must not be designed with weld junctions and/or wire terminus ends in the ocular area, such that in the event of a weld separation, the wire ends could come into contact with the ocular area.
- 7.2 The headgear/equipment must survive all test protocols substantially intact and ready for use.
- 7.3 Projections: Any internal rigid projections that may contact the wearer's head during impact shall be covered to reduce the likelihood of injury.

8 Materials

- 8.1 Materials used in the headgear/equipment shall be durable and resistant to exposure to sun, rain, cold, dust, vibration, perspiration and products likely to be applied to the skin or hair. Materials known to cause skin irritation or disease shall not be used. Lining materials, if used, may be detachable for washing. If hydrocarbons, cleaning fluids, paints or transfers/decals or other additions may affect the headgear/equipment adversely, a warning shall be provided.

9 Labeling & Instructions

- 9.1 Each headgear/equipment shall be permanently and legibly labeled or marked in a manner such that the following information can be easily read and is not obscured in any manner.
- 9.1.1 Name of Manufacturer
- 9.1.2 Model Designation
- 9.1.3 Size
- 9.2 Each headgear/equipment shall be permanently and legibly labeled or marked in a manner such that the following additional information can be easily read without removing any permanent component. These labels shall contain a signal word which shall not be obscured in any manner:

- 9.2.1 A label that warns the user that no headgear can protect against all possible impacts; and, that for maximum performance, the headgear/equipment must be fitted and attached properly to the wearer's head in accordance with the manufacturer's fitting instructions.
- 9.2.2 A label that warns the user that the headgear/equipment can be damaged by accidental, incidental or intentional contact with common substances (for example, certain solvents, cleaners, hair treatments, etc.) and that this damage may or may not be visible to the user. This label should also list any recommended cleaning agents or procedures, or both.
- 9.2.3 Warnings: Each headgear/equipment shall have appropriate warning information as called for in the individual performance specifications.
- 9.3 Individual standard performance specifications may require additional labeling or marking on the interior or exterior of the product, or both.
- 9.4 A permanent and legible label or mark that denotes the month and year of manufacture that can be easily read without removing any permanent component. If this mark or label requires a "code" to determine month and year, such code shall be made available upon request.
- 9.4.1 In cases where a manufacturer does not authorize or allow recertification of a helmet model, those models must have a label that prescribes a useable life of certification. Companies must be able to support such lifetime claims.
- 9.5 Helmets that are not to be recertified as mandated by the manufacturer must bear a label stating the recommended life of the product. Companies will be expected to provide proof that the helmets meet the standards requirements throughout the recommended life of the product.
- 9.6 Each headgear/equipment shall have fitting/positioning instructions provided. Including any attachment instructions for authorized accessories, where applicable.
- 9.7 Warning and other informational requirements, unless in quotations, need not contain the exact wording but must effectively communicate to the end user the required information using the same or similar language. Except where in quotes the language provided in the standards is exemplary only.
- 9.8 A legible, permanent replica of one of the appropriate seals (shown below) shall appear on the exterior of the headgear/equipment, see note below seals.

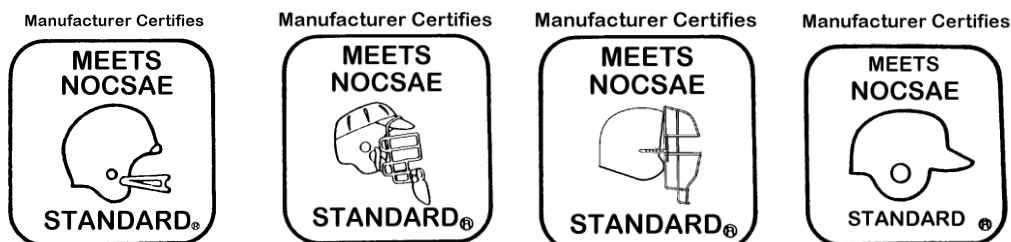



NOTE: You must have an executed, valid license agreement with NOCSAE to use any of the NOCSAE logos at any time. NOCSAE, the NOCSAE seals/logos, and the National Operating Committee on Standards for Athletic Equipment are registered marks and the exclusive property of the Committee. Use of the marks in any manner is prohibited without prior written permission of the NOCSAE Board of Directors. In place of manufacturer certifies the manufacturer may use its own name i.e., xyz company certifies "MEETS NOCSAE STANDARD" This seal may be scaled so long that it remains legible.

- 9.9 Packaging for products that a manufacturer has certified to meet the NOCSAE standard may include a legible replica of the following seal



Replicas of NOCSAE seals that appear on the products that a manufacturer has certified to meet the NOCSAE standard are to be placed only on the appropriate products as specified in individual NOCSAE standards

10 Samples for Testing

- 10.1 Headgear/equipment shall be tested complete, in the condition as offered for sale or use unless specified otherwise in an individual performance specification.
- 10.2 Headgear/equipment used for testing must be selected in a random manner.

11 Sample Size

- 11.1 A statistically relevant sample must be tested.¹

12 Conditioning Environments

- 12.1 Ambient Temperature - Expose headgear/equipment to testing environment for a minimum of four hours.
- 12.2 High Temperature - Expose headgear/equipment to conditioned temperature of 115 ± 5 F° (46 ± 3 C°) for a minimum of four hours and a maximum of twenty-four (24) hours.

¹

For guidance on what is an acceptable sample size, interested parties can refer to Military Standard Series 105, ISO 9000 Standard Series or ANSI/ASQL Standard Series.

- 12.3 Testing Environment - The tests must be performed in an environment with a temperature of 72 F°, ± 5 F° (22 C°, ± 2 C°). Always monitor laboratory conditions (temperature and humidity) prior to testing and at periodic intervals during testing.
- 12.4 When performing conditioned environment temperature testing, the first impact shall occur between the 1st and 2nd minute after removing the sample from the conditioning environment. Successive impacts in each location shall occur 75 seconds (± 15 sec) after the first impact, etc. If the sample cannot be tested within these time constraints, the sample must be returned to the conditioning environment for a minimum of 3 minutes for each minute the sample was out of the conditioning environment. Conditioning must be complete before testing can resume on that sample.

13 Test Headforms

Physical properties of the NOCSAE headforms to be used in this standard drop test method are given in Table 1 and Figure 1.¹

TABLE 1
APPROXIMATE MEASUREMENTS OF NOCSAE HEADFORMS † - inches (mm)
(See Figure 1)

POINTS OF MEASURE	HEADFORM SIZES		
	6 5/8	7 1/4	7 5/8
1 Head Breadth	5.63 (143)	5.98 (152)	6.46 (164)
2 Maximum brow width (frontal diameter)	4.65 (118)	5.20 (132)	5.52 (140)
3 Ear hole to ear hole (bitragion diameter)	5.24 (133)	5.51 (140)	6.06 (154)
4 Maximum jaw width (bigonial diameter)	4.13 (105)	4.65 (118)	5.08 (129)
5 Head length (glabella landmark to back of head)	7.09 (180)	7.87 (200)	8.15 (207)
6 Outside eye corner (external canthus) to back of head	6.22 (158)	6.81 (173)	7.32 (186)
7 Ear hole (tragion) to back of head	3.50 (89)	3.86 (98)	4.25 (108)
8 Ear hole to outside corner of eye (tragion to ext. canthus)	2.72 (69)	2.95 (75)	3.07 (78)
9 Ear hole to top of head (tragion to vertex)	4.72 (120)	5.24 (133)	5.67 (144)
10 Eye pupil to top of head	4.13 (105)	4.53 (115)	4.96 (126)
11 Ear hole ‡ to jaw angle (tragion to gonion)	3.31 (84)	3.03 (77)	2.84 (72)
12 Bottom of nose to point of chin (subnasal to menton)	2.56 (65)	2.80 (71)	3.03 (77)
13 Top of nose to point of chin (nasion to menton)	4.45 (113)	4.88 (124)	5.39 (137)
14 Head circumference	21.02 (534)	22.68 (576)	24.17 (614)
15 Head weight including mounting interface	9.08 lb (4.12 kg)	10.8 lb (4.90 kg)	13.08lb (5.93 kg)

† The anthropometric measurements are based upon references 2.3 and 2.4.

‡ The right ear of each headform shall be removed flush with the skin surface.

14 Reports

- 14.1 Maintain complete test records for all testing. The records can be stored on paper, electronically or photographically. The test report shall contain the following information:

¹ Headforms are available from Southern Impact Research Center

- 14.1.1 Name and location of the test laboratory.
- 14.1.2 Name of Laboratory Technician.
- 14.1.3 Model and size of each headgear tested, name of manufacturer and date of manufacture.
- 14.1.4 Observed temperatures in each conditioning and testing environment.
- 14.1.5 Impact results incorporating the impact locations, drop velocity, Severity Index and Peak Acceleration for each impact.
- 14.1.6 Date of test and any other data required by this standard or individual standard performance specification.

15 Impact Test Instruments and Equipment

- 15.1 Recommended Guide Assembly Including Carriage Assembly (See Figure 3 and Table 2)
- 15.2 Impact Surfaces
 - 15.2.1 Calibration MEP Pad - (See Appendix for specifications)
 - 15.2.2 ½" Test MEP Pad - (See Appendix for specifications)
 - 15.2.3 1/8" Faceguard Test MEP Pad - (See Appendix for specifications)
- 15.3 Triaxial Accelerometer
- 15.4 Impact Recording Equipment¹
- 15.5 Headforms (Physical properties given in Table 1 and Figure 1)
 - 15.5.1 Small NOCSAE Headform
 - 15.5.2 Medium NOCSAE Headform
 - 15.5.3 Large NOCSAE Headform

16 Instrument Calibration

- 16.1 Verify that the instrumentation used for data acquisition is correctly executing algorithms that will result in appropriate SI levels $\pm 2\%$ across a range of about 600 SI to about 2500 SI with particular emphasis at 1200 SI.

¹ The data acquisition systems currently used are (1), a dedicated KME data analyzer available from K. M. E. Company in Troy, MI or, (2), a standard PC equipped with the appropriate data acquisition components may also be used.

17 Headform Calibration

- 17.1 Each headform must be calibrated prior to testing utilizing a calibration MEP pad and drop locations/velocities as identified in the NOCSAE Calibration Pad Qualification (or Re-Qualification) Report for the particular MEP Calibration Pad to be used. Velocities specified for headform calibration have a very narrow tolerance in order to assure valid headform response. Resultant SI for each of the three (3) positions on each headform must be 1200 SI, $\pm 2\%$, when headforms are impacted in accordance with the specified velocities. At a minimum, calibration must be performed each time a headform is attached to the drop carriage.
- 17.2 The MEP Calibration Pad shall be requalified at least annually at the laboratory¹ specified by NOCSAE.

18 System Check

- 18.1 A system check must be performed after each calibration and just prior to testing product.
- 18.2 A system check must again be performed upon the completion of a product testing session.
- 18.3 Any variation between 18.1 and 18.2 must be 7% or less.

19 Impact Attenuation Tests

- 19.1 The maximum Severity Index and peak acceleration cannot exceed the limits specified in the individual standard performance specification.
- 19.2 Each headgear/equipment shall be impacted in accordance with the requirements of the individual standard performance specification with respect to drop velocities, impact locations and test conditions.
- 19.3 The time between successive impacts in each location shall be 75 ± 15 seconds.
- 19.4 Standard Impact Locations [Medium Headform²](see Figure 2)

NOTE: The anvil and the impact surface shall be centered as close as possible to the impact site on the headform. The anvil must be bolted securely to the base plate with both bolts tightened prior to impact.

- 19.4.1 Front (F) - Located in the median plane approximately 1-in above the anterior intersection of the median and reference plane.
- 19.4.2 Front Boss (FB) - A point approximately in the 45 degree plane from the median plane measured clockwise and located approximately above the reference plane.

¹ Southern Impact Research Center

² Impact locations are determined by the carriage, stem and rotator assemblies per established drawings and are approximated on the medium head for reference. Periodic inspection of the components is required to maintain impact location integrity.

- 19.4.3 Side (S) - Located approximately at the intersection of the reference and Coronal planes on the right side of the headform.
- 19.4.4 Rear Boss (RB) – A point approximately on the reference plane located approximately 135 degrees clockwise from the anterior intersection of the median and reference planes.
- 19.4.5 Rear (R) – Approximately at the posterior intersection of the median and reference planes.
- 19.4.6 Top (T) - Located approximately at the intersection of the median and Coronal planes. The right hand carriage release ring should be used for this drop.
- 19.4.7 Random – The random location maybe selected from any point within the impact area so that the initial point of contact between the headform and the impact surface shall be on or above the lines that define the impact area as specified in the individual performance specification. Random locations must allow rotator assembly to be locked in the position selected.

20 Helmet Positioning/Fit

- 20.1 Manufacturing fitting instructions shall be used to obtain a reasonable fit on the test headform. In the event that these instructions are unclear or result in a fit that is likely to yield erroneous test results, the technician shall fit the helmet to the best of their ability on the most appropriate test headform.
- 20.2 The ear holes (if so equipped) of the helmet should be concentric with the headform ear index holes and the lower front rim of the helmet should be aligned with the nose gauge (or the equivalent measurements), using the notch/gauge that is appropriate for the headform in use.
- 20.3 A manufacturer of a helmet may require a different position by specifying the lower front rim distance from the basic plane as measured vertically from the basic plane on the median plane. If so specified, then that resulting position shall be used instead of the nose gauge position.

NOTE: Since fit is subjective on humanoid headforms, the headform specified by the manufacturer, or the headform closest to matching the labeled helmet size, should be used as a beginning point. In any case, the resulting fit must be reasonable as determined by the test technician. Where, in the opinion of the technician, the specified headform is incorrect and would yield erroneous test results, the technician **must** substitute a different headform to obtain a better fit.

A measure as to the reasonableness of fit can be conducted as follows: After positioning the helmet as above, with the chin strap and/or other retention straps unfastened, you should be able to smoothly rotate the headform to the inverted (Top) position without any visible motion of the helmet. This is one way to determine if a helmet is too large for a given headform. This method may not be accurate if the helmet has a faceguard attached. If the helmet is too small for a headform, one way to judge this is to measure or observe the distance from the top of the headform to the inside surface of the helmets fitting system. If the top or crown of the headform and the inside of the helmet are not in contact, the helmet is likely too small for that particular headform. In any case, the final decision as to reasonableness of fit rests with the test technician/laboratory.

This standard is subject to revision at any time by the responsible technical authority and must be reviewed every five years and if not revised either reapproved or withdrawn. Your comments are invited for either revision, modification or creation of additional standards and should be addressed to NOCSAE's Executive Director. Check the web at www.nocsae.org to obtain the latest version of a standard.

This standard is copyrighted by NOCSAE 11020 King St. Suite 215, Overland Park, Kansas 66210 USA. Copies may be obtained from the NOCSAE web site at www.nocsae.org

APPENDIX

I. Specifications

A. Impact Surfaces -

1. 3" Calibration MEP Pad

- a) Dimensions - Approximately a 3 inch (7.6 cm) thick by 6-inch (15.2 cm) diameter pad.
- b) Material - Molded from polyurethane thermoplastic elastomer.
- c) Performance - Must provide a 232 g response (± 40 g's) when impacted at 5.44 meters/second ($\pm 2\%$) by a falling impactor having a spheroidal radius of 73 mm (± 1 mm) and a total drop mass of 5 kg (± 5 gm). The carriage and follower assembly cannot exceed 20% of the total drop mass, per ASTM F 1446.
- d) All new and annually requalified calibration MEP pads shall not require headform drop velocities greater than a 5.5 ft/s (1.68 m/s) deviation from the norm as determined by the requalification lab in any position for any headform size.
- e) Additional performance characteristics may be required as deemed appropriate by NOCSAE's specified re-qualification laboratory.

2. 1/2" Test MEP Pad

- a) Dimensions - Approximately a 1/2 inch (1.3 cm) thick by 6-inch (15.2 cm) diameter pad.
- b) Material - Molded from polyurethane thermoplastic elastomer.
- c) Performance - Must provide a 385 g response (± 38 g's) when impacted at 3.9 meters/second ($\pm 2\%$) by a falling impactor having a spheroidal radius of 73 mm (± 1 mm) and a total drop mass of 5 kg (± 5 gm). The carriage and follower assembly cannot exceed 20% of the total drop mass, per ASTM F 1446.

3. 1/8" Faceguard Test MEP Pad

- a) Dimensions - Approximately a 1/8 inch (3.2 mm) thick by 6-inch (15.2 cm) diameter pad.
- b) Material - Molded from polyurethane thermoplastic elastomer.
- c) Performance - Must have a durometer of greater than 70 Shore "A".

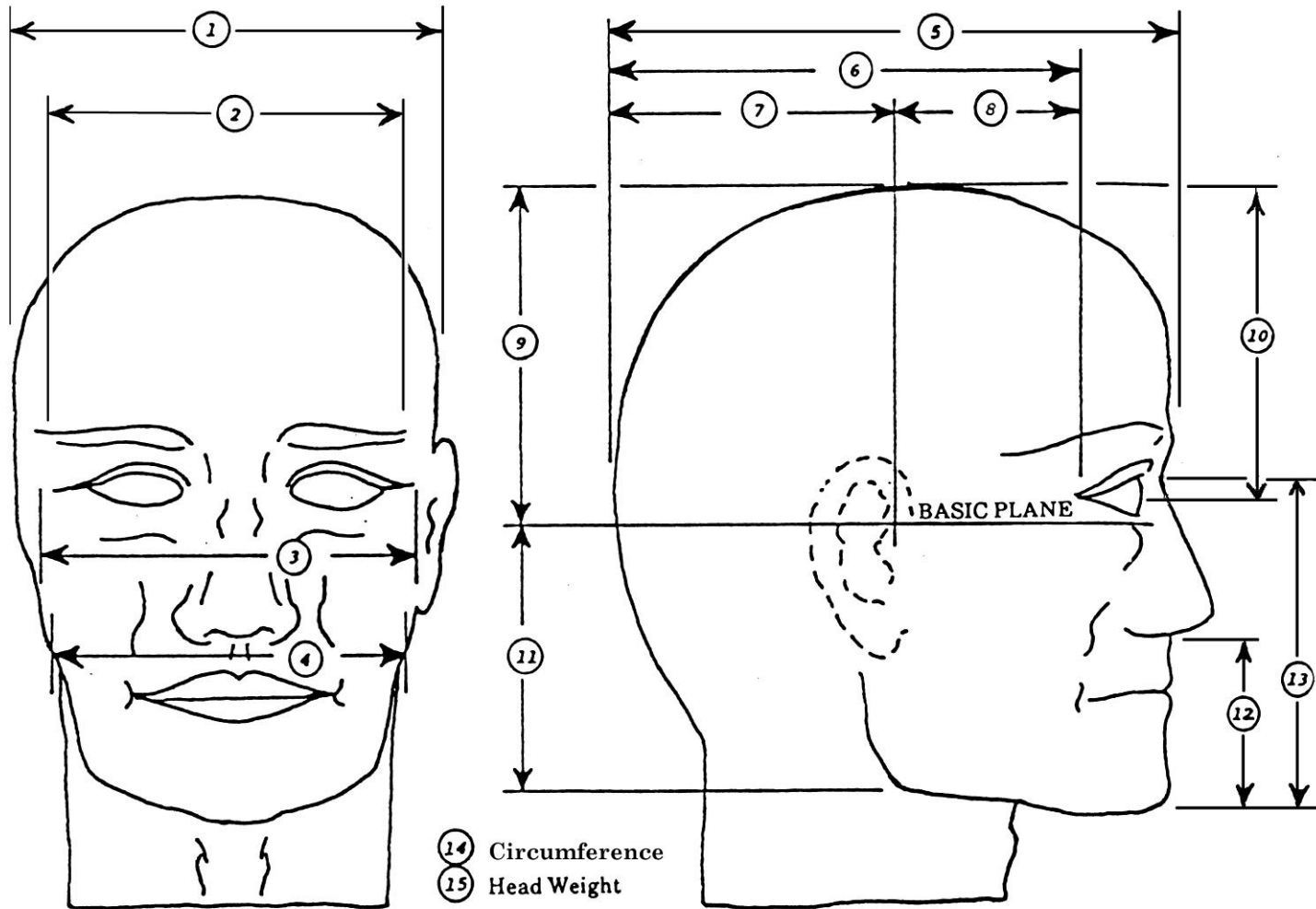

DIMENSIONING OF NOCSAE HEAD MODELS
(See Table 1)

Figure 1

Note: The right ear has been removed from the models to facilitate right side head impacts. Models with both ears intact are available for special purposes. Models able to accept a nine-array accelerometer block are available. Details of measurement locations are available from NOCSAE's Technical Director.

APPROXIMATE IMPACT LOCATIONS

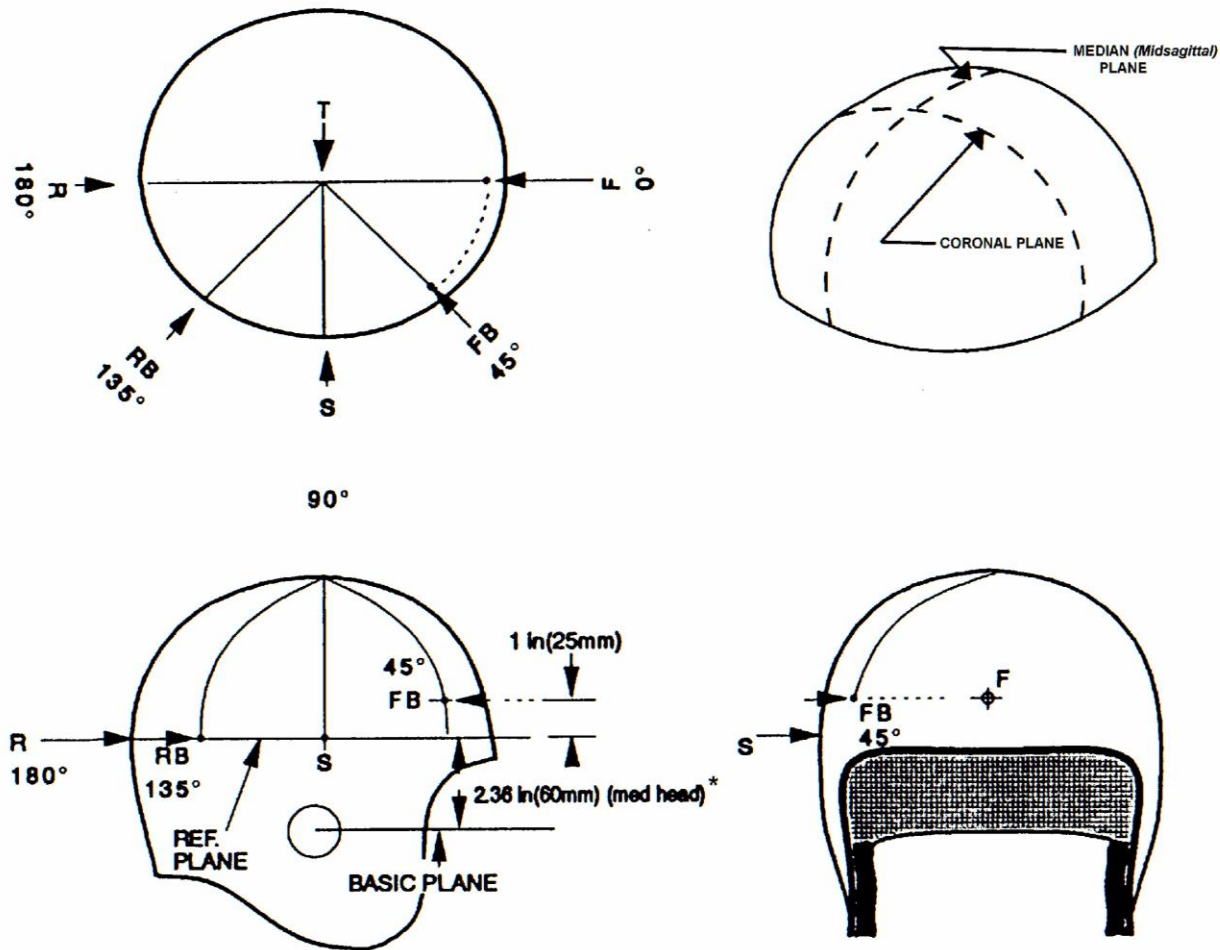

Figure 2

*For the small headform, the REFERENCE PLANE is 2.16 inches above the BASIC PLANE. For the large headform, the REFERENCE PLANE is 2.48 inches above the BASIC PLANE.

The random location may be selected from any point within the allowed impact area. Specific limitations on random impacts, if any, will be specified in the individual performance specification for each headgear.

Random locations chosen must allow the rotator assembly to be locked in the position selected.

Impact Area – specified in the individual performance specification for each headgear.

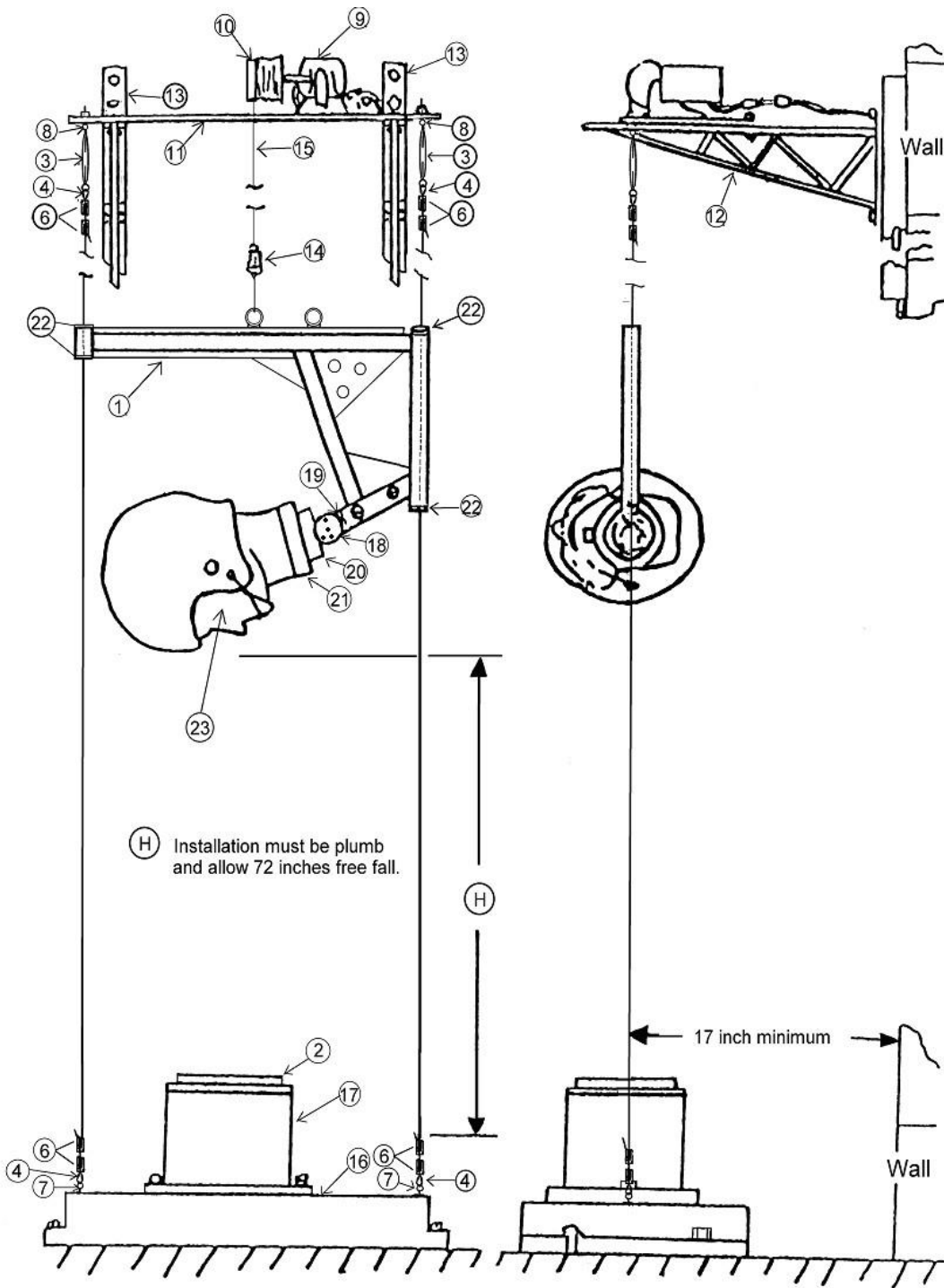

Figure 3

TABLE 2
HEADGEAR DROP TEST MECHANICAL SYSTEM COMPONENTS

CODE	DESCRIPTION	AVAILABILITY ¹	DRAWINGS AVAILABLE	SIRC PART NO.
1	Drop Carriage	SIRC ²	Yes ³	1001
2	½" MEP Testing Pad	SIRC	No	1006
2	1/8" MEP Faceguard Testing Pad	SIRC	No	1007
2	3" MEP Calibration Pad	SIRC	No	1005
3	Hook-eye Turnbuckle, Forged Steel, 3/8" with a 6" take-up	SIRC/H ⁴	N	1043
4	1/8" Wire Rope Thimble	SIRC/M ^C ⁵	N	1044
5	1/8" Spring Music Wire	SIRC/M ^C ⁶	N	1045
6	1/8" Wire Rope, Tiller Rope Clamp, Bronze	SIRC/M ^C ⁷	N	1046
7	3/8" 16 x 3 " Eye Bolt	SIRC/H	N	1041
8	3/8" Forged Eye Bolt	SIRC/H	N	1040
9	Right Angle DC Hoist Motor	SIRC/G ⁸	N	2000
Not Shown	DC Motor Speed Controller (Reversible)	SIRC/G ⁹	N	2001
10	Single Groove Sheave (Pulley), 3 ¾"	SIRC/G ¹⁰	N	2002
11	Top Mount Plate	SIRC	Y	2003
12	18" Top Channel Bracket	SIRC/H	N	2004
13	Wall Mount Channel Bracket, 4' x 1 5/8"	SIRC/H	N	2005
14	Mechanical Release System	SIRC	Y	2006
15	Lift Cable, Wire Rope, 20' Coil	SIRC/H	N	2007
16	Anvil Base Plate	SIRC	Y	2010
17	Anvil	SIRC	Y	2011
18	Headform Adjuster	SIRC	Y	2012
19	Headform Rotator Stem	SIRC	Y	2013
20	Headform Threaded Lockring	SIRC	Y	2016
21	Headform Collar	SIRC	y	2014
22	Nylon Bushing	SIRC	Y	1803
23	Small Headform	SIRC	N	1100
23	Medium Headform	SIRC	N	1101
23	Large Headform	SIRC	N	1102

¹ While all of these components are available from SIRC, alternatives are offered.

² Southern Impact Research Center (SIRC).

³ SIRC will make these drawings available for those who would prefer to have this component machined on their own.

⁴ While this component is available from SIRC, you may also be able to purchase it from a large hardware store.

⁵ While this component is available from SIRC, you may also purchase this component from McMaster-Carr Supply Company.

⁶ While this component is available from SIRC, you may also purchase this component from McMaster-Carr Supply Company.

⁷ While this component is available from SIRC, you may also purchase this component from McMaster-Carr Supply Company.

⁸ While this component is available from SIRC, you may also purchase this component from W. W. Grainger, Inc.

⁹ While this component is available from SIRC, you may also purchase this component from W. W. Grainger, Inc.

¹⁰ While this component is available from SIRC, you may also purchase this component from W. W. Grainger, Inc.

MAY, 1998 MODIFICATIONS/REVISIONS

- Added a definition under Section 3 for “Permanent (label)”
- Removed the word “optional” from 3.8.
- Added the Catcher’s helmet logo to 9.1.6
- **Revision** - Changed the performance specification of the ½” testing pad to 385g ± 10% in Appendix 1.A.2.
- Miscellaneous grammatical improvements.

MAY, 2000 MODIFICATIONS/REVISIONS

- **Revision** - Changed the performance specification of the 3” Calibration Pad to 232g ± 40 g’s in Appendix 1.A.2.
- Added a definition for the edge of a helmet in 3.7.
- Modified Section 17 and removed Chart 1 to reflect the new requirements for drop heights being related to a specific MEP Calibration pad.

JUNE, 2001 MODIFICATIONS/REVISIONS

- Modified Preface to define a revision vs. a modification of a NOCSAE Standard.
- Added a definition under Section 3 for “Chin Strap.”
- Added a definition under Section 3 for “Critical Sizes.”
- Added a definition under Section 3 for “Legible.”
- Added a definition under Section 3 for a “Neck Strap”.
- Added a definition under Section 3 for “Permanent (component).”
- Added a definition under Section 3 for “Primary Retention System.”
- Added a definition under Section 3 for “Retention System”.
- Added a definition under Section 3 for “Signal Word.”.
- Reorganized most of Section 9 for simplicity.
- In Section 9, noted that other types of markings are permissible besides a label.
- Modified introductory paragraphs for the two first sub-sections of Section 9.
- Removed the word “exact” from, added the word “legible” to old 9.1.4 (now 9.5).
- Deleted old 9.1.5.
- Removed vendor Part Numbers from Table 2.

JANUARY, 2002 MODIFICATIONS/REVISIONS

- Modified 20.1 to recognize that the nose gauge cannot always be used for every style of helmet.
- Change the focus on impact locations from protective coverage to area of impacts.
 - Added Impact Area to table of contents.
 - Changed definition of Edge 3.8 page 4.
 - Added definition for Impact Area 3.15 page 4.
 - Changed Fig 2 text to clarify Impact Area.
 - Changed 19.4.7 to clarify Random Impact Location.
- Changed page A-6 code 7 SIRC part number 1050 to SIRC part number 1041-3/8 – 16 x 3 “ Eye Bolt (HDG).

JANUARY, 2004 MODIFICATIONS/REVISIONS

- Modified 12.2 to allow a temperature tolerance and to better describe the need to be sure the conditioned temperature of a helmet is still in an acceptable conditioned state before performing another type of test on that helmet.
- Added NOCSAE Hockey Helmet Logo to Section 9.6.
- **Revision** - Changed 19.4.7 and the wording in Figure 2 to specify random Impact location changed from 3 inches (75MM) to 1 inch (25MM)
- Changed naming convention and added NOCSAE logo to cover page.
- Added definition of Bill
- Added definition of Visor
- Modified section 3.7.2 to address testing of very small sized models of helmets
- Added definition of similar model
- Added definition of headgear model
- Added definition of shimming
- Added definition of Figure
- Modified definition of critical size
- Modified table 1 to reflect new head models
- Modified preface to add “sunset” clause
- Corrected grammar in the preface and made several typographical corrections throughout
- Added clarification to label section regarding quotations in the requirements
- Clarified Triaxial placement requirements, and filtering language
- Changed footnote for instrumentation system to remove GHI systems
- Clarified impact locations as being defined by carriage, stem and rotator
- Changed effective date language in the preface

MARCH, 2004 MODIFICATIONS/REVISIONS

- Changed seal/logo document to allow use of the manufacturers name in place of the word Manufacturer

AUGUST, 2004 MODIFICATIONS/REVISIONS

- Added Anthropometric references relating to the latest headform
- Clarified definition of edge to include headgear
- Clarified Random location, 19.4.7 and Figure 2

FEBRUARY, 2005 MODIFICATIONS/REVISIONS

- Clarified definition of NOCSAE headform to include instrumented.
- Modified response requirement for 3”MEP and hardness for 1/8” MEP to reflect current specifications.

DECEMBER, 2005 MODIFICATIONS/REVISIONS

- Added face protector to face guard definition section 3.11.
- Clarified temperature recording requirements in sections 12 and 14.
- Modified Figure 2 title.

JANUARY, 2006 MODIFICATIONS/REVISIONS

- **Revision** – Added requirement to provide proof of certification via certified independent laboratory

APRIL, 2006 MODIFICATIONS/REVISIONS

- Added reference to ASTM F 1446
- Added section 17.2, Calibration MEP requalification requirement
- Modified Appendix, Calibration MEP specification requirements
- Section 9.4 moved and became 9.1.4 Month and year of manufacture cannot be obscured in any manner.
- Added Including any attachment instructions for authorized accessories, where applicable in section 9.4

DECEMBER, 2006 MODIFICATIONS/REVISIONS

- Clarified definition of nose gauge.
- Clarified definition of permanent label/markings.
- Clarified Section 20 in regards to helmet positioning and fit
- Clarified Section 9.1.4 in regards to decoding a mark.
- Updated table 1 based on headform landmarks
- Updated figure 1 text (note)
- Added definition for intact
- Clarified Section 7.1 in regards to design considerations
- Modified Section 9 placement of date code

JANUARY, 2007 MODIFICATIONS/REVISIONS

- Modified Section 9 to add package labeling

JUNE, 2007 MODIFICATIONS/REVISIONS

- Deleted the word Drop in documents title
- Added soccer shin guard seal and added “/equipment” throughout the document
- Added pass/fail criteria to list of critical test parameters for clarification.

JANUARY, 2008 MODIFICATIONS/REVISIONS

- Added definition of eye protector, modified definition of face protector
- Added definition of Hardware
- Defined method of determining random impact site locations
- Corrected section numbering in section 9

MAY, 2008 MODIFICATIONS/REVISIONS

- **Revision** – Added statement in preface on tolerances of mechanical systems and impact locations
- Added definition of Common Substances and clarified labeling requirement
- Corrected typographical and formatting errors
- Added labeling requirement for non re-certifiable product
- Added 9.4.1 to address product certification life

AUGUST, 2008 MODIFICATIONS/REVISIONS

- Added statement in certification section concerning requirements of discontinued product.

DECEMBER, 2008 MODIFICATIONS/REVISIONS

- Added Baseball Helmet NOCSAE logo to section 9.8

MAY, 2010 MODIFICATIONS/REVISIONS

- Clarified footnote 1 page 12 and Figure 3

JANUARY, 2011 MODIFICATIONS/REVISIONS

- **Revision-** Specified drop velocity measurement requirements instead of drop heights. Corrected typos. Updated headform weights.