

**STANDARD PERFORMANCE
SPECIFICATION FOR
NEWLY MANUFACTURED
HOCKEY HELMETS**

NOCSAE DOC (ND) 030 - 11m11

Prepared By



**NATIONAL OPERATING COMMITTEE
ON STANDARDS FOR ATHLETIC EQUIPMENT**

Revised – February, 2011
Effective no earlier than February, 2012

TABLE OF CONTENTS

Scope.....	1
Referenced Documents.....	1
Specific Terminology.....	1
Sample Size	1
Helmet Preparation	2
Testing Sequence	2
Retention Testing	2
Helmet Stability Testing.....	2
Impact Attenuation Tests.....	3
General	3
Helmet Drop Tests	3
Helmet Projectile Tests	4
Test Requirements.....	5
Labels and Warning	5
JULY, 2004 MODIFICATIONS/REVISIONS	13
February 2011, MODIFICATIONS/REVISIONS	13

1. Scope

- 1.1. This standard specification establishes performance requirements for new hockey helmets as supplied by manufacturers.
- 1.2. **All testing and requirements of this standard specification must be in accordance with NOCSAE DOC.001 and NOCSAE DOC.021, except where modified herein.**
- 1.3. *This standard does not purport to address all of the safety problems, if any, associated with its use. It is the responsibility of the user of this standard to establish appropriate safety and health practices and determine the applicability of regulatory limitations prior to use.*

2. Referenced Documents

- 2.1. STANDARD DROP TEST METHOD AND EQUIPMENT USED IN EVALUATING THE PERFORMANCE CHARACTERISTICS OF PROTECTIVE HEADGEAR, NOCSAE DOC.001
- 2.2. STANDARD PROJECTILE IMPACT TEST METHOD AND EQUIPMENT USED IN EVALUATING THE PERFORMANCE CHARACTERISTICS OF PROTECTIVE HEADGEAR/PROJECTILES, NOCSAE DOC.021

3. Specific Terminology

- 3.1. See Section 3, NOCSAE DOC.001
- 3.2. Low Temperature: Expose product to conditioned temperature of $-3^{\circ}\text{F} \pm 3^{\circ}\text{F}$ ($-19^{\circ}\text{C} \pm 2^{\circ}\text{C}$) for at least four hours.
- 3.3. High Temperature: Expose product to conditioned temperature of $100^{\circ}\text{F} \pm 3^{\circ}\text{F}$ ($39^{\circ} \pm 1^{\circ}\text{C}$) for at least four hours and a maximum of twenty-four (24) hours.

NOTE: When performing conditioned environment temperature testing, the first impact shall occur between the 1st and 2nd minute after removing the sample from the conditioning environment. The second impact shall occur 75 seconds (± 15 sec) after the first impact, etc. If the sample cannot be tested within these time constraints, the sample must be returned to the conditioning environment for a minimum of 3 minutes for each minute the sample was out of the conditioning environment. Conditioning must be complete before testing can resume on that sample.

4. Sample Size

- 4.1. See Section 11, NOCSAE DOC.001
- 4.2. At least four (4) of each model in each critical size must be tested. Two (2) will be tested at ambient; one tested at high temperature; and one tested at low temperature. Helmets of a given model with a size smaller than 6 5/8 **may** not fit the smallest NOCSAE headform. In that event, testing of that size is waived so long as the other sizes of that model have been tested and meet all requirements.

- 4.3. To obtain a reasonable fit (as determined by the test technician) for testing purposes, helmets larger than size 7 5/8 **may** require "shim" pads to be inserted between the largest NOCSAE headform and the interior of the helmet, opposite from the impact site.

5. Helmet Preparation

- 5.1. See Section 10, NOCSAE DOC.001
- 5.2. Face Guards - Helmets must be tested without face guards or face guard specific hardware. Any components of the headgear not associated with the faceguard (i.e. nose bumpers, front padding, etc.) must be securely attached to the helmet using appropriate means prior to impact testing.

6. Testing Sequence

- 6.1. The retention and roll-off tests described below shall be performed prior to any of the impact tests

7. Retention Testing

- 7.1. The subject helmet, while seated on a head shaped platform, shall be subjected to a dynamic strength retention test on the primary retention system using a Retention System Strength and Extension apparatus (see Figure 4). Said apparatus shall include two metal bars each with a diameter of 0.5 ± 0.02 in (12.7 ± 0.5 mm) that have a center distance of 3.0 ± 0.04 in (76.0 ± 1 mm).

The retention system fastening device shall be aligned with the strap fixture so that no part of the retention system fastening device shall contact the strap fixture prior to release of the drop mass. The entire dynamic test apparatus shall hang freely on the retention system. The entire mass of the support assembly, excluding drop weight, must be 15.5 lb (7.03 kg) $\pm 5\%$.

- 7.2. A 9 ± 0.2 lb (4.1 ± 0.08 kg) drop mass shall be allowed to free fall onto the stop anvil from a height of 1.5 feet ± 0.25 inch (45 cm ± 6 mm). The retention system shall remain intact without elongating by more than 1.25 inches (31.75 mm).

A second test from a drop height of 3 feet ± 0.25 inch (91 cm ± 6 mm) shall be performed and the retention system shall release allowing the helmet to be removed from the headform.

- 7.3. A helmet at high temperature and one at low temperature shall be subjected to these same two tests.

8. Helmet Stability Testing

- 8.1. A helmet stability (roll-off) stand is depicted in Figure 5 and shall include a guide rod and stop anvil (see Figure 6) similar to that used in the Retention System test, minus the strap fixture (two rods). This guide apparatus shall weigh 2.5 ± 0.5 lb (1.13 ± 0.23 kg).
- 8.2. A cable and attached hook connect the guide rod to the far edge of the helmet. The cable and hook shall weigh less than 0.45 lb (0.2 kg). The hook shall engage no less than $\frac{1}{2}$ linear inches (12.7 mm) of the helmet edge.

- 8.3. An ambient temperature helmet shall be affixed to the correct size NOCSAE headform in accordance with the manufacturer's instructions with only the primary retention system adjusted as described in those instructions. This helmet shall then be subjected to a positional stability test by allowing a 9 lb (4.08 kg) drop mass to pull on the back edge of the helmet when dropped from a height of 2 feet (0.61 m). During this test the headform will be canted downwards at a 45° angle from vertical and facing the floor. The helmet shall remain on the headform upon the completion of this test.

9. Impact Attenuation Tests

9.1. General

- 9.1.1. The hockey puck used must be an official hockey puck and shall conform to the International Ice Hockey Federation (IIHF) standard that is: Diameter equals $3 \pm .02$ inch (76.2 ± 0.5 mm), Thickness equals 1 ± 0.02 inch (25.4 ± 0.5 mm), Mass equals 5.5 to 6 ounces (156 to 170 g), Hardness equals 92 ± 0.5 IRH (International Rubber Hardness) at $32^\circ \pm 2^\circ$ F ($0^\circ \pm 1^\circ$ C).

9.2. Helmet Drop Tests

- 9.2.1. Impact locations are described in Section 19, NOCSAE DOC.001.
- 9.2.2. Impacts shall be conducted on the Test MEP pad (see Section 15.2.2, NOCSAE DOC.001).
- 9.2.3. Helmets shall be impacted in accordance with Table 1 below and as depicted in Figure 1 (see also Figure 2). The ambient conditioned helmets are impacted first to determine which shall be the low and high temperature tested locations.
- 9.2.4. At least two (2) locations, not to exceed four (4) locations, regardless of the number of helmets tested at ambient, are to be selected for the high and low temperature impacts. This is accomplished by determining which of the 60 inch ambient temperature locations tested yielded the two highest severity indexes on each of the ambient samples. Those locations shall be tested on each of the samples subjected to high and low temperature testing.
- 9.2.5. The random location chosen cannot be less than 1 inch (25 mm) from any standard impact location.

TABLE 1

LOCATION - DROP velocities – ft/s (m/s)
(All drop velocities must be within +3% -0%)

	FRONT	RIGHT SIDE	RIGHT F. BOSS	RIGHT R. BOSS	REAR	TOP	RANDOM
Ambient Temperature	11.34 (3.46)	11.34 (3.46)	11.34 (3.46)	11.34 (3.46)	11.34 (3.46)	11.34 (3.46)	11.34 (3.46)
	16.04 (4.88)	16.04 (4.88)	16.04 (4.88)	16.04 (4.88)	16.04 (4.88)	16.04 (4.88)	16.04 (4.88)
	17.94 (5.46)	17.94 (5.46)	17.94 (5.46)	17.94 (5.46)	17.94 (5.46)	17.94 (5.46)	
High * Temperature	17.94 (5.46)	17.94 (5.46)	17.94 (5.46)	17.94 (5.46)	17.94 (5.46)	17.94 (5.46)	16.04 (4.88)
Low * Temperature	17.94 (5.46)	17.94 (5.46)	17.94 (5.46)	17.94 (5.46)	17.94 (5.46)	17.94 (5.46)	16.04 (4.88)

NOTE: Impacts at ambient must be conducted in sequence from the lowest drop velocity through the highest.

* The locations to be impacted for both the high and low temperature impacts varies and depends upon the results of the ambient temperature impacts completed first; see 9.2.3 and 9.2.4 above. New (non-impacted) helmets are to be used for the high and low temperature impacts, a separate sample for each.

9.3. Helmet Projectile Tests

9.3.1. Impact locations are described in Section 19, NOCSAE DOC.001.

9.3.2. See Section 5.1, NOCSAE DOC.021.

9.3.3. The head model will be positioned with its impact site located 24 ± 0.25 inch (610 ± 6 mm) from the muzzle (or point at which the puck is released).

9.3.4. Each submitted sample helmet shall be impacted with a hockey puck in accordance with Table 2 and as depicted in Figure 3.

9.3.5. One location is selected for the high temperature impact by determining which of the 63 mph impacts at ambient temperature locations tested yielded the highest severity index.

TABLE 2

LOCATION - MILES PER HOUR (m/sec)
(All speeds must be $\pm 3\%$)

	RIGHT SIDE	RIGHT REAR BOSS	REAR	RANDOM
Ambient Temperature	63 (28)	63 (28)	63 (28)	63 (28)
High Temperature*	63 (28)	63 (28)	63 (28)	63 (28)

Notes: * The high temperature condition impact must be done after the ambient temperature impacts. Impact velocity must be within 3% of the specified velocity for that particular projectile.

10. Test Requirements

- 10.1. The peak severity index of any impact shall not exceed 1200 SI.
- 10.2. The 11.34 ft/s impacts designated in Table 1 must not exceed 300 SI.
- 10.3. Helmet repositioning during testing is anticipated. Any structural changes or other changes that take place during impact testing which result in un-restorable, loosening of the fit (see Section 20, NOCSAE DOC.001) shall be cause for failure. In the case of helmets “shimmed” as per section 4.3, the replacement or repositioning of shims is allowed.
- 10.4. A passing helmet model is able to withstand all impacts at an acceptable SI and meets all other requirements when tested in accordance with this performance specification.

11. Labels and Warning

- 11.1. See Sections 9 in both NOCSAE DOC.001 and NOCSAE DOC.021.
- 11.2. Each helmet shall have permanently affixed to the exterior of the shell a clearly legible statement which can be easily read without removal of any decal tape, other temporary material or permanent part, which contains language which effectively communicates to the purchaser and user the following information, using the same or similar language:

WARNING

NO HELMET CAN PREVENT ALL HEAD OR ANY NECK INJURIES A PLAYER MIGHT RECEIVE WHILE PARTICIPATING IN HOCKEY.

DO NOT USE THIS HELMET TO BUTT AN OPPOSING PLAYER. THIS IS IN VIOLATION OF THE HOCKEY RULES AND SUCH USE CAN RESULT IN SEVERE HEAD OR NECK INJURIES, PARALYSIS OR DEATH TO YOU AND POSSIBLE INJURY TO YOUR OPPONENT.

- 11.3. A permanent, exact replica of this seal must appear legibly on the exterior of the shell.



NOTE: You must have an executed, valid license agreement with NOCSAE to use any of the NOCSAE logos at any time. NOCSAE, the NOCSAE seals/logos, and the National Operating Committee on Standards for Athletic Equipment are registered marks and the exclusive property of the Committee. Use of the marks in any manner is prohibited without prior written permission of the NOCSAE Board of Directors. In place of manufacturer certifies the manufacturer may use it's own name i.e., xyz company certifies “MEETS NOCSAE STANDARD”

This standard is subject to revision at any time by the responsible technical authority and must be reviewed every five years and if not revised either reapproved or withdrawn. Your comments are invited either for revision, modification or creation of additional standards and should be addressed to NOCSAE's Executive Director. Check the web at www.nocsae.org to obtain the latest version of a standard.

This standard is copyrighted by NOCSAE 11020 King St. Suite 215, Overland Park, Kansas 66210 USA. Copies may be obtained from the NOCSAE web site at www.nocsae.org

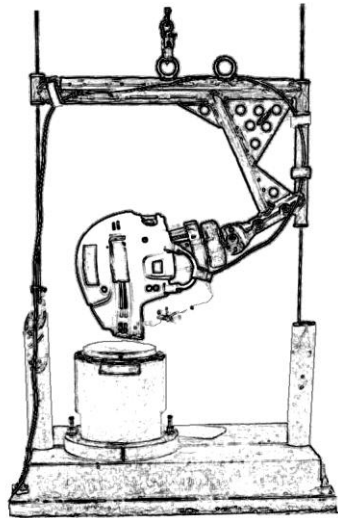

Front Impacts

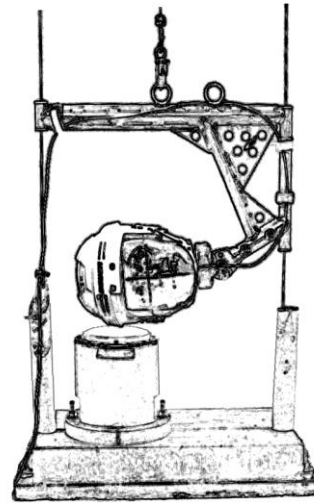

Right Side Impacts

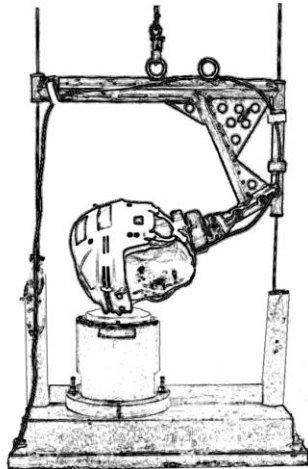

Right Front Boss Impacts

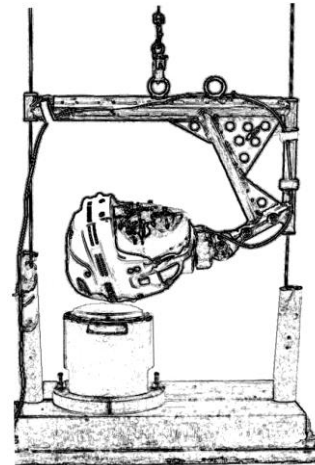

Right Rear Boss Impacts

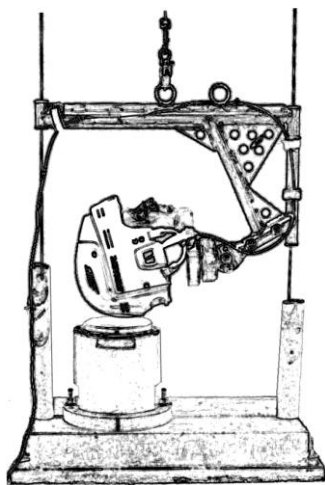

Rear Impacts

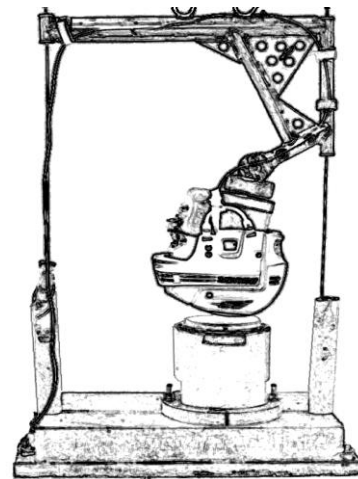

Top Impacts

Figure 1

IMPACT LOCATIONS

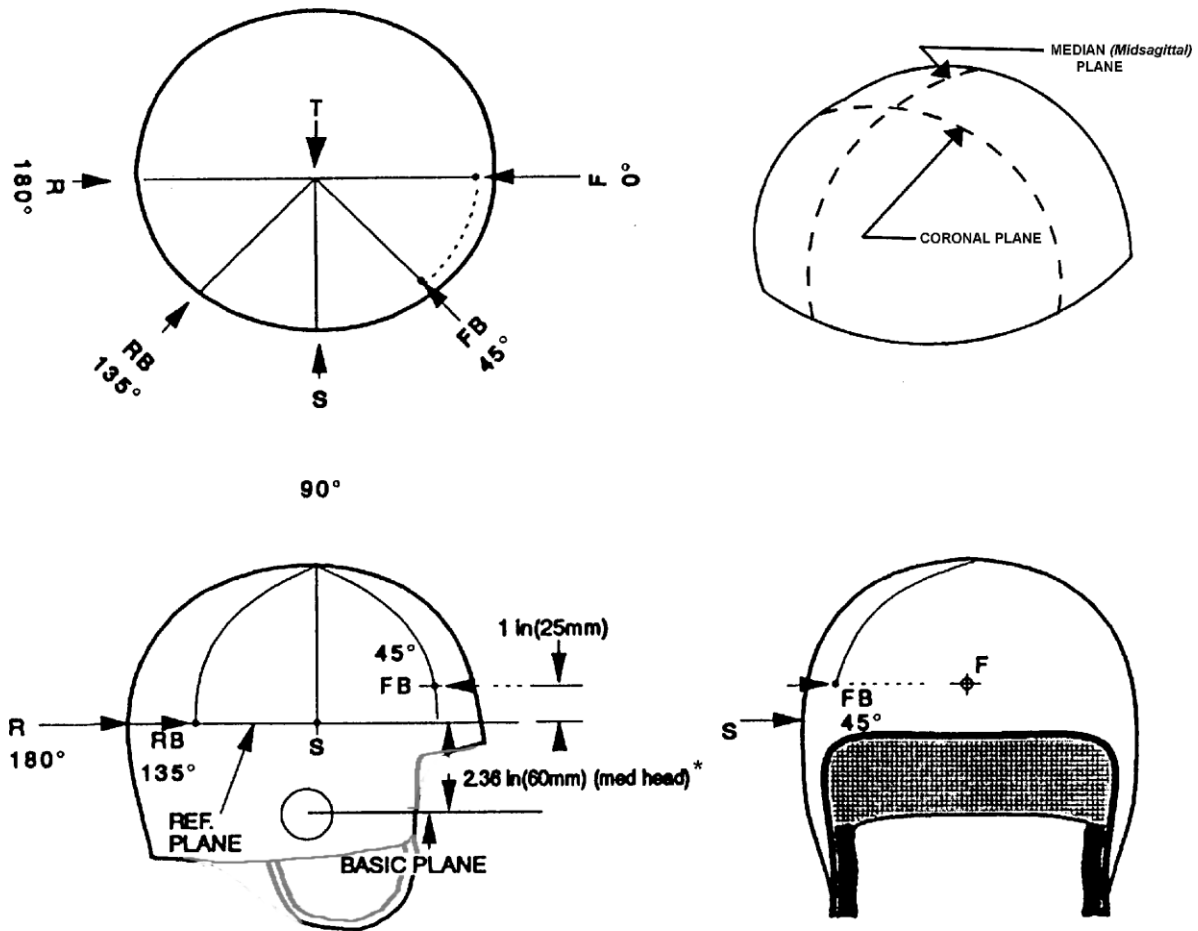

* For the small headform the REFERENCE PLANE is 2.16 inches above the BASIC PLANE. For the large headform the REFERENCE PLANE is 2.48 inches above the BASIC PLANE.

The random location may be selected from any point within the allowed impact area but not closer than 1 inch (25 mm) from the edge of the helmet nor less than 1 inch (25 mm) from any previous impact.

Random locations chosen must allow the rotator assembly to be locked in the position selected.

Impact Area - for a helmet that is to be tested on the medium headform*, the impact area must include all locations on the headform above the BASIC PLANE rearward of a location 2.5 inches (64 mm) forward of where the BASIC PLANE intersects with the CORONAL PLANE and any point on or above the REFERENCE PLANE in front of that same intersection.

* For the small headform use 2.25 inches (57 mm) and for the large headform use 2.75 inches (70 mm).

Figure 2

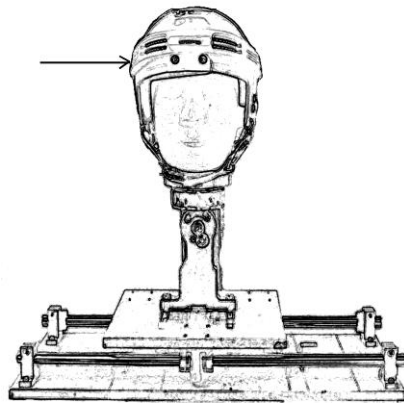

Right Side

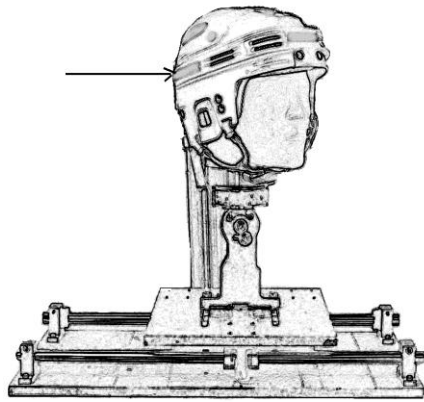

Right Rear Boss

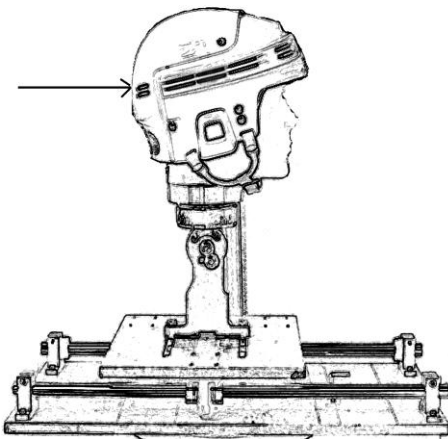

Rear

Figure 3

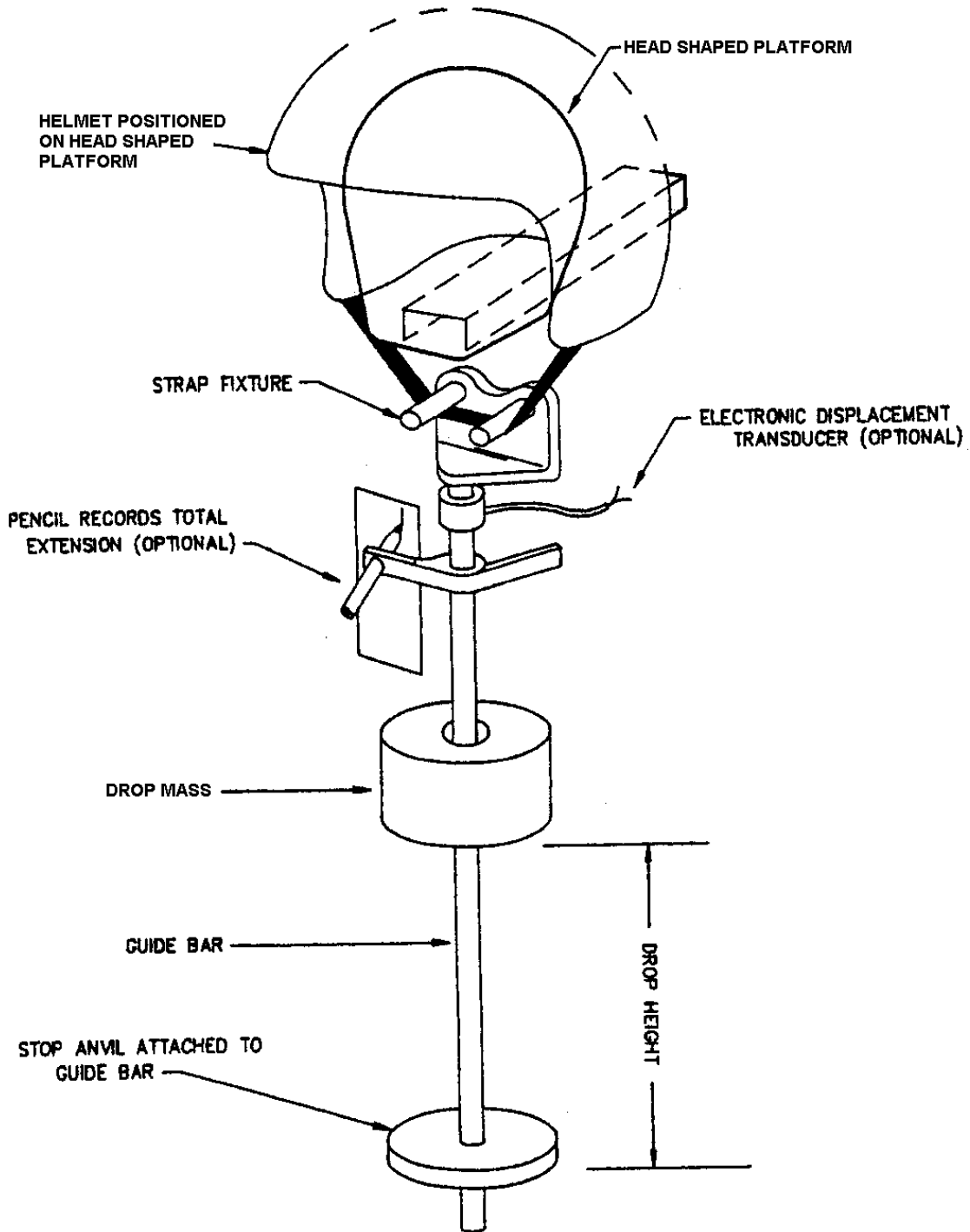

Figure 4

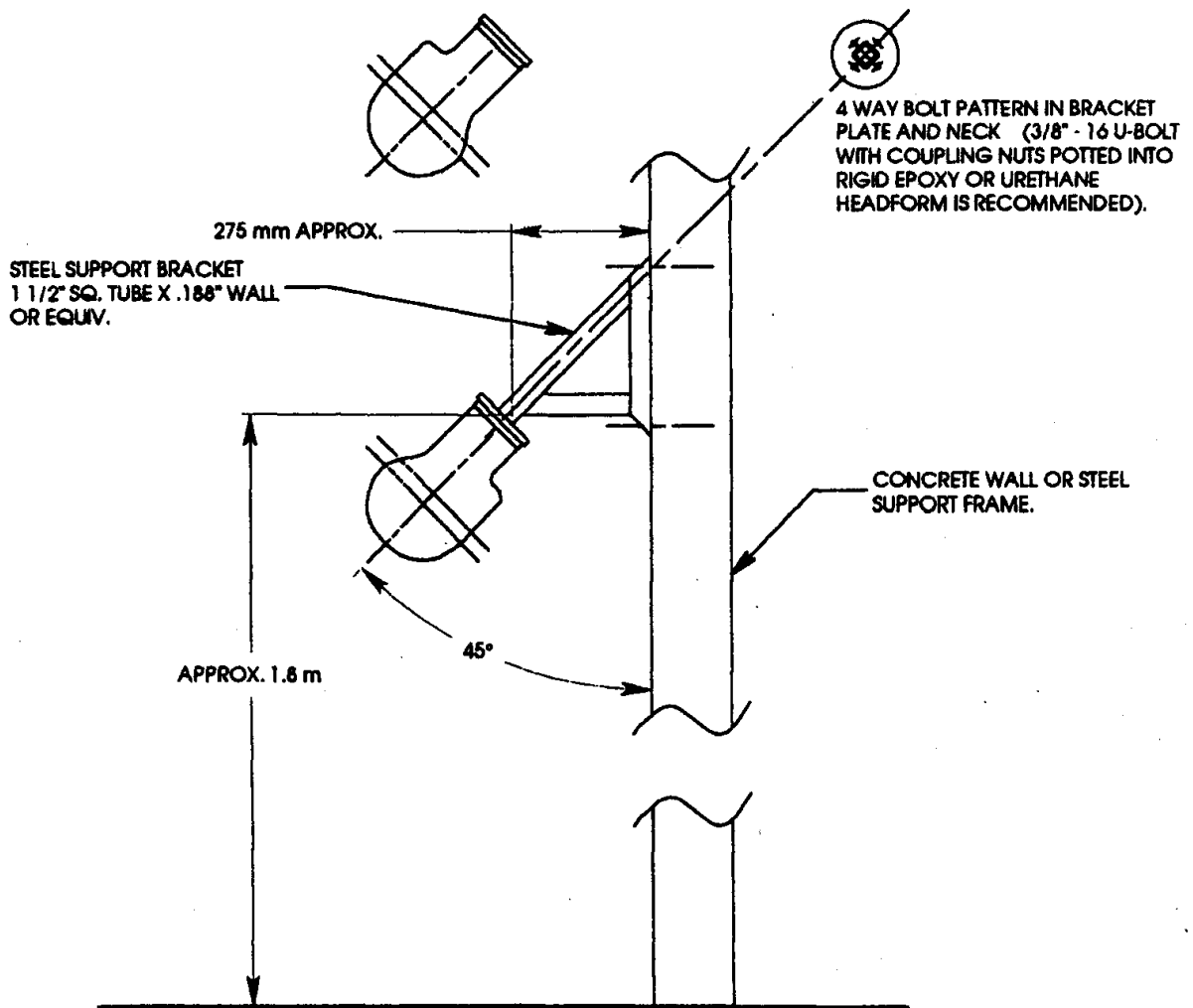

FIG. 13 Stability Test Stand

Figure 5

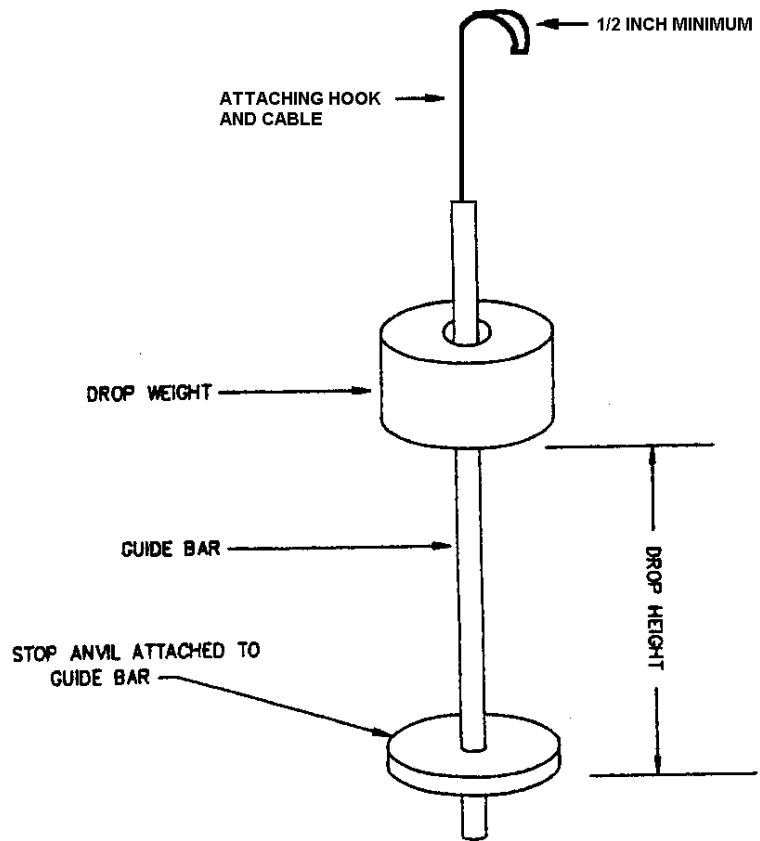

Figure 6

JULY, 2004 MODIFICATIONS/REVISIONS

- Modified section 9.2.4 to clarify that each high/low temperature sample gets impacted at each of the highest SI locations based on the ambient test. This can be no less than two nor more than four locations.

FEBRUARY 2011, MODIFICATIONS/REVISIONS

- **REVISION-** Change drop heights to drop velocities. Moved test requirements to section 10. Clarified test requirements.